

Grizzly *Industrial, Inc.*®

MODEL G9744Z 10"x18" Metal Cutting Bandsaw OWNER'S MANUAL



COPYRIGHT © JULY, 2006 BY GRIZZLY INDUSTRIAL, INC.
**WARNING: NO PORTION OF THIS MANUAL MAY BE REPRODUCED IN ANY SHAPE
OR FORM WITHOUT THE WRITTEN APPROVAL OF GRIZZLY INDUSTRIAL, INC.**
#PC8343 PRINTED IN TAIWAN



WARNING!

This manual provides critical safety instructions on the proper setup, operation, maintenance and service of this machine/equipment.

Failure to read, understand and follow the instructions given in this manual may result in serious personal injury, including amputation, electrocution or death.

The owner of this machine/equipment is solely responsible for its safe use. This responsibility includes but is not limited to proper installation in a safe environment, personnel training and usage authorization, proper inspection and maintenance, manual availability and comprehension, application of safety devices, blade/cutter integrity, and the usage of personal protective equipment.

The manufacturer will not be held liable for injury or property damage from negligence, improper training, machine modifications or misuse.



WARNING!

Some dust created by power sanding, sawing, grinding, drilling, and other construction activities contains chemicals known to the State of California to cause cancer, birth defects or other reproductive harm. Some examples of these chemicals are:

- **Lead from lead-based paints.**
- **Crystalline silica from bricks, cement and other masonry products.**
- **Arsenic and chromium from chemically-treated lumber.**

Your risk from these exposures varies, depending on how often you do this type of work. To reduce your exposure to these chemicals: Work in a well ventilated area, and work with approved safety equipment, such as those dust masks that are specially designed to filter out microscopic particles.

Table of Contents

INTRODUCTION	3
Foreword	3
Contact Info.....	3
Machine Data Sheet.....	4
Identification	6
Control Panel	7
SECTION 1: SAFETY	8
Safety Instructions for Machinery.....	8
Additional Safety Instructions for Metal Cutting Bandsaws	10
SECTION 2: CIRCUIT REQUIREMENTS	11
220V Single-Phase	11
SECTION 3: SETUP	12
Setup Safety.....	12
Items Needed for Setup	12
Unpacking	12
Inventory.....	13
Hardware Recognition Chart.....	14
Clean Up	15
Site Considerations	15
Moving & Placing Base Unit.....	16
Mounting to Shop Floor.....	16
Shipping Bracket.....	17
Workstop	17
Chip Tray.....	18
Feed Stop.....	18
Recommended Adjustments	19
Test Run.....	19
SECTION 4: OPERATIONS	20
Operation Safety	20
Vise	20
Blade Guide Arms	22
Blade Selection	23
Blade Speed.....	24
Feed Rate	24
Coolant System.....	25
Cutting Fluid	26
Operation Tips.....	27
SECTION 5: ACCESSORIES	28

SECTION 6: MAINTENANCE	30
Schedule	30
Cleaning	30
Lubrication.....	30
SECTION 7: SERVICE	32
Troubleshooting.....	32
Blade Change	34
Blade Tension & Tracking.....	35
Blade Guide Bearings	36
Squaring Blade to Table	37
Electrical Components	38
Model G9744Z 220V Wiring Diagram	39
Blade Guide Parts Breakdown.....	40
Drive Wheel Parts Breakdown	41
Main Parts Breakdown	42
Parts List	43
WARRANTY AND RETURNS	46

INTRODUCTION

Foreword

We are proud to offer the Model G9744Z Metal Cutting Bandsaw. This machine is part of a growing Grizzly family of fine metalworking machinery. When used according to the guidelines set forth in this manual, you can expect years of trouble-free, enjoyable operation and proof of Grizzly's commitment to customer satisfaction.

We are pleased to provide this manual with the Model G9744Z. It was written to guide you through assembly, review safety considerations, and cover general operating procedures. It represents our effort to produce the best documentation possible.

The specifications, drawings, and photographs illustrated in this manual represent the Model G9744Z as supplied when the manual was prepared. However, owing to Grizzly's policy of continuous improvement, changes may be made at any time with no obligation on the part of Grizzly. For your convenience, we always keep current Grizzly manuals available on our website at **www.grizzly.com**. Any updates to your machine will be reflected in these manuals as soon as they are complete. Visit our site often to check for the latest updates to this manual!

Contact Info

If you have any comments regarding this manual, please write to us at the address below:

Grizzly Industrial, Inc.
c/o Technical Documentation Manager
P.O. Box 2069
Bellingham, WA 98227-2069

We stand behind our machines. If you have any service questions or parts requests, please call or write us at the location listed below.

Grizzly Industrial, Inc.
1203 Lycoming Mall Circle
Muncy, PA 17756
Phone: (570) 546-9663
Fax: (800) 438-5901
E-Mail: techsupport@grizzly.com
Web Site: <http://www.grizzly.com>





MACHINE DATA SHEET

Customer Service #: (570) 546-9663 • To Order Call: (800) 523-4777 • Fax #: (800) 438-5901

MODEL G9744Z 10" X 18" METAL CUTTING BANDSAW

Product Dimensions:

Weight770 lbs.
Length/Width/Height 68 x 24 x 41-1/2 in.
Foot Print (Length/Width)..... 47 x 19 in.

Shipping Dimensions:

TypeWood Slat Crate
Content.....Machine
Weight.....860 lbs.
Length/Width/Height..... 69 x 29-1/2 x 47-1/2 in.

Electrical:

Switch..... Push Button ON/OFF
Switch Voltage 220V
Cord Length 5 ft.
Cord Gauge 14 gauge
Recommended Breaker Size 20 amp
PlugNo

Motors:

Main

Type.....TEFC Capacitor Start Induction
Horsepower..... 2 HP
Voltage..... 220V
Prewired 220V
Phase Single
Amps 15A
Speed..... 1725 RPM
Cycle 60 Hz
Number Of Speeds 1
Power Transfer Gear
Bearings Shielded and Lubricated

Main Specifications:

Operation Info

Blade Speeds..... 114, 196, 288, 377 FPM
Std. Blade Length 129-3/8 in.



Cutting Capacities

Angle Cuts	45°–90°
Vise Jaw Depth	12-1/2 in.
Vise Jaw Height	5 in.
Max Capacity Rect. Height At 90°	5 in.
Max Capacity Rect. Width At 90°	18-3/8 in.
Max Capacity Rnd. Width At 90°	10 in.
Max Capacity Rect. Height At 45°	6 in.
Max Capacity Rect. Height At 30°	10 in.
Max Capacity Rect. Width At 30°	14 in.
Max Capacity Rnd. At 30°	10 in.
Max Capacity Rect. Width At 45°	9-3/8 in.
Max Capacity Rnd. At 45°	6 in.

Construction

Table Construction	Precision Ground Cast Iron
Wheel Construction Upper	Machined Cast Iron
Wheel Construction Lower	Machined Cast Iron
Body Construction	Cast Iron
Base Construction	Pre-Formed Steel
Wheel Cover Construction	Pre-Formed Steel
Paint	Epoxy

Other

Wheel Size	13 in.
Blade Guides Upper	Ball Bearing
Blade Guides Lower	Ball Bearing
Coolant Capacity	2-1/2 gal.

Table Info

Floor To Cutting Area Height	23 in.
------------------------------------	--------

Other Specifications:

ISO Factory	ISO 9001
Country Of Origin	Taiwan
Warranty	1 Year
Serial Number Location	Grizzly ID Label
Assembly Time	15 minutes

Features:

- Centralized Control Panel on Top of the Saw Bow
- Heavy-duty Steel Base
- Adjustable Hydraulic Downfeed
- Worm Gear Box has Hardened and Ground Gears
- Quick Release Vise for Fast Job Changes
- Miter Cutting Ability
- Blade Wheels have Heavy-duty Ball Bearings
- Magnetic Safety Switch
- Coolant Pump and Reservoir



Identification

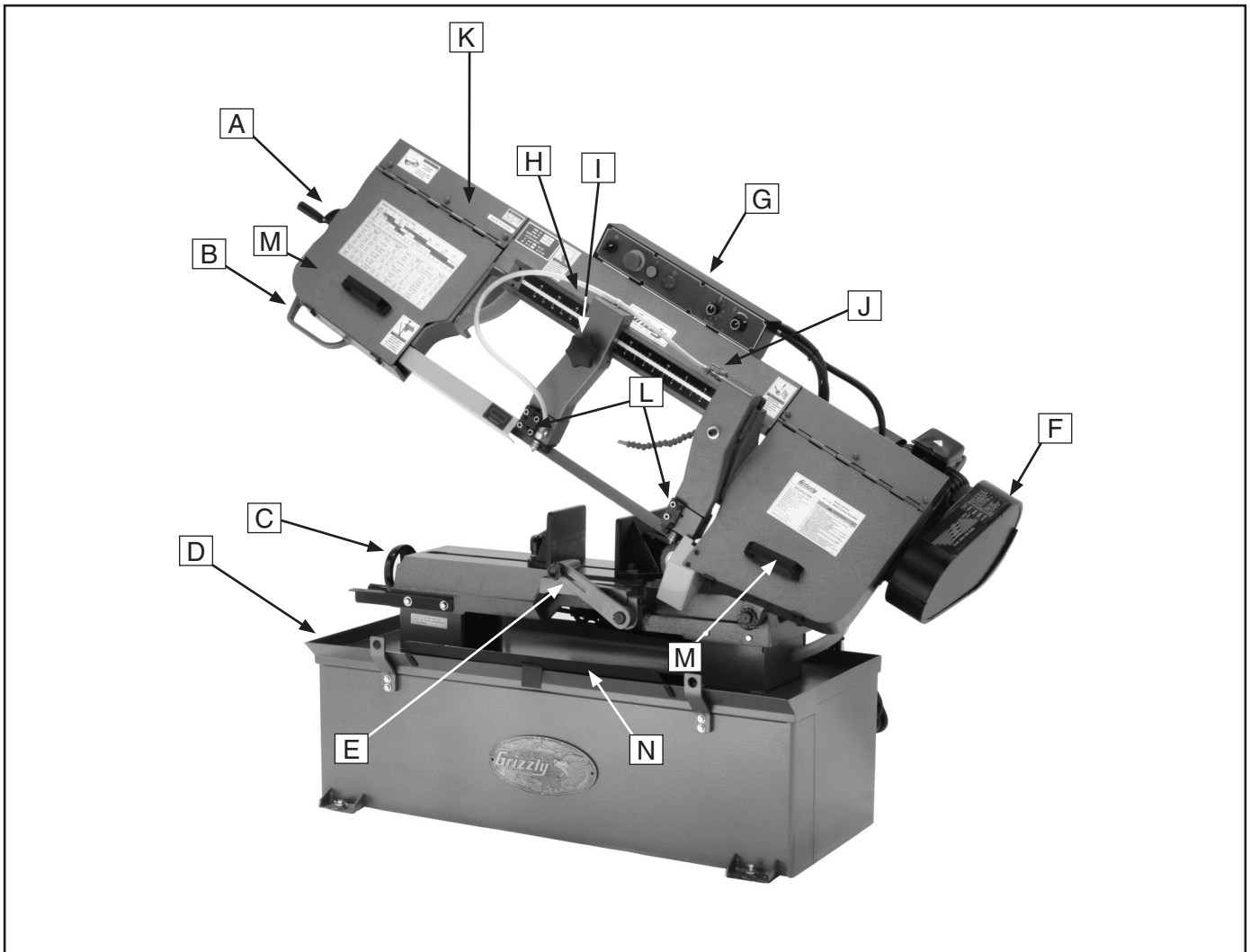

Figure 1. G9744Z machine identification.

- A. Blade Tension Handwheel
- B. Lift Handle
- C. Vise Handwheel
- D. Coolant Drip Pan
- E. Work Stop
- F. Pulley Cover
- G. Control Panel
- H. Blade Guide Scale
- I. Blade Guide Knob
- J. Coolant Valve Control
- K. Bow
- L. Blade Guides
- M. Wheel Covers
- N. Chip Tray



Control Panel

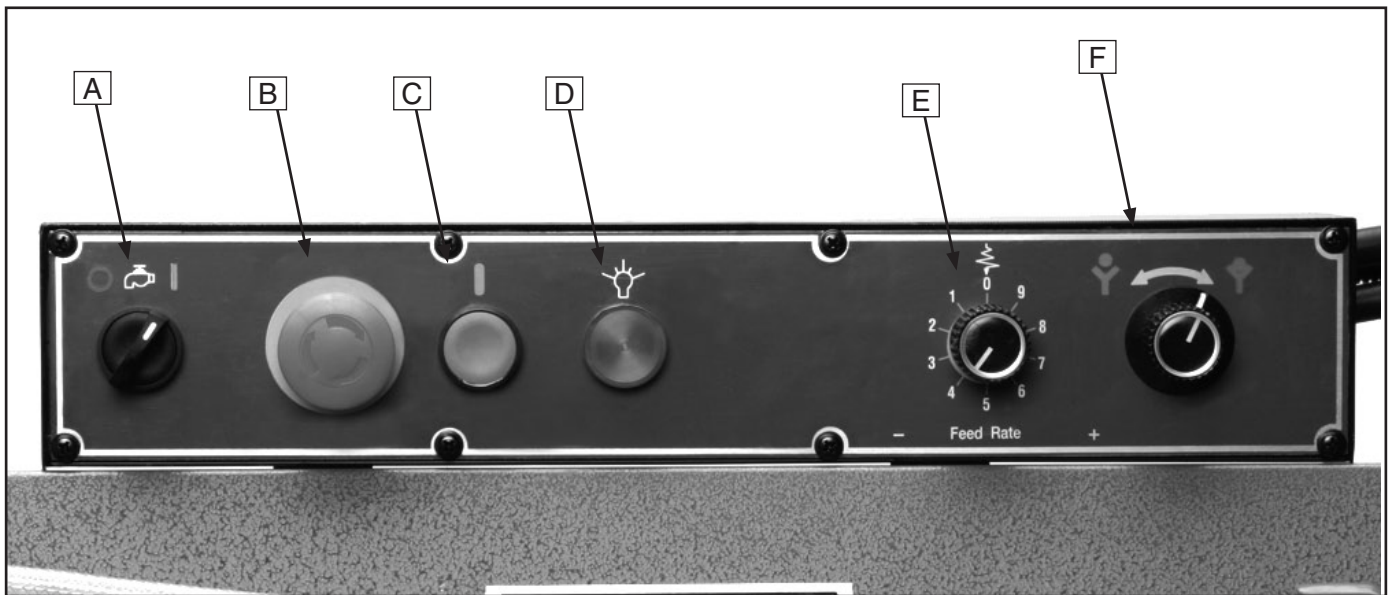

Figure 2. G9744Z control panel.

- A. **Coolant Pump Switch:** Turns the coolant pump **ON**.
- B. **EMERGENCY STOP/OFF Button:** Interrupts power to the system and turns the motor **OFF**. Twist the button until it pops out to re-energize the system. Also works as a standard OFF button.

*Note: The bandsaw has an automatic shut-off (limit switch) that turns the motor and coolant pump **OFF** at the bottom of the cut.*
- C. **START Button:** Turns the motor **ON**.
- D. **Power Light:** When lit, indicates that system is energized and machine is ready to operate.
- E. **Feed Rate Dial:** Fine tunes the feed rate by controlling the hydraulic valve. Range is from 0 (slowest) to 9 (fastest).
- F. **Feed Control Knob:** Turning the knob to the left lowers the bow at the feed rate you have set. Turning the knob to the right locks the bow in position.



SECTION 1: SAFETY

WARNING

For Your Own Safety, Read Instruction Manual Before Operating this Machine

The purpose of safety symbols is to attract your attention to possible hazardous conditions. This manual uses a series of symbols and signal words which are intended to convey the level of importance of the safety messages. The progression of symbols is described below. Remember that safety messages by themselves do not eliminate danger and are not a substitute for proper accident prevention measures.

 **DANGER** Indicates an imminently hazardous situation which, if not avoided, **WILL** result in death or serious injury.

 **WARNING** Indicates a potentially hazardous situation which, if not avoided, **COULD** result in death or serious injury.

 **CAUTION** Indicates a potentially hazardous situation which, if not avoided, **MAY** result in minor or moderate injury. It may also be used to alert against unsafe practices.

NOTICE This symbol is used to alert the user to useful information about proper operation of the machine.

WARNING

Safety Instructions for Machinery

- 1. READ THROUGH THE ENTIRE MANUAL BEFORE STARTING MACHINERY.** Machinery presents serious injury hazards to untrained users.
- 2. ALWAYS USE ANSI APPROVED SAFETY GLASSES WHEN OPERATING MACHINERY.** Everyday eyeglasses only have impact resistant lenses, they are NOT safety glasses.
- 3. ALWAYS WEAR AN NIOSH APPROVED RESPIRATOR WHEN OPERATING MACHINERY THAT PRODUCES DUST.** Wood dust is a carcinogen and can cause cancer and severe respiratory illnesses.
- 4. ALWAYS USE HEARING PROTECTION WHEN OPERATING MACHINERY.** Machinery noise can cause permanent hearing damage.
- 5. WEAR PROPER APPAREL. DO NOT** wear loose clothing, gloves, neckties, rings, or jewelry which may get caught in moving parts. Wear protective hair covering to contain long hair and wear non-slip footwear.
- 6. NEVER OPERATE MACHINERY WHEN TIRED, OR UNDER THE INFLUENCE OF DRUGS OR ALCOHOL.** Be mentally alert at all times when running machinery.



WARNING

Safety Instructions for Machinery

7. **ONLY ALLOW TRAINED AND PROPERLY SUPERVISED PERSONNEL TO OPERATE MACHINERY.** Make sure operation instructions are safe and clearly understood.
8. **KEEP CHILDREN AND VISITORS AWAY.** Keep all children and visitors a safe distance from the work area.
9. **MAKE WORKSHOP CHILD PROOF.** Use padlocks, master switches, and remove start switch keys.
10. **NEVER LEAVE WHEN MACHINE IS RUNNING.** Turn power **OFF** and allow all moving parts to come to a complete stop before leaving machine unattended.
11. **DO NOT USE IN DANGEROUS ENVIRONMENTS.** DO NOT use machinery in damp, wet locations, or where any flammable or noxious fumes may exist.
12. **KEEP WORK AREA CLEAN AND WELL LIT.** Clutter and dark shadows may cause accidents.
13. **USE A GROUNDED EXTENSION CORD RATED FOR THE MACHINE AMPERAGE.** Undersized cords overheat and lose power. Replace extension cords if they become damaged. DO NOT use extension cords for 220V machinery.
14. **ALWAYS DISCONNECT FROM POWER SOURCE BEFORE SERVICING MACHINERY.** Make sure switch is in OFF position before reconnecting.
15. **MAINTAIN MACHINERY WITH CARE.** Keep blades sharp and clean for best and safest performance. Follow instructions for lubricating and changing accessories.
16. **MAKE SURE GUARDS ARE IN PLACE AND WORK CORRECTLY BEFORE USING MACHINERY.**
17. **REMOVE ADJUSTING KEYS AND WRENCHES.** Make a habit of checking for keys and adjusting wrenches before turning machinery **ON**.
18. **CHECK FOR DAMAGED PARTS BEFORE USING MACHINERY.** Check for binding and alignment of parts, broken parts, part mounting, loose bolts, and any other conditions that may affect machine operation. Repair or replace damaged parts.
19. **USE RECOMMENDED ACCESSORIES.** Refer to the instruction manual for recommended accessories. The use of improper accessories may cause risk of injury.
20. **DO NOT FORCE MACHINERY.** Work at the speed for which the machine or accessory was designed.
21. **SECURE WORKPIECE.** Use clamps or a vise to hold the workpiece when practical. A secured workpiece protects your hands and frees both hands to operate the machine.
22. **DO NOT OVERREACH.** Keep proper footing and balance at all times.
23. **MANY MACHINES WILL EJECT THE WORKPIECE TOWARD THE OPERATOR.** Know and avoid conditions that cause the workpiece to "kickback."
24. **ALWAYS LOCK MOBILE BASES (IF USED) BEFORE OPERATING MACHINERY.**
25. **BE AWARE THAT CERTAIN DUST MAY BE HAZARDOUS** to the respiratory systems of people and animals, especially fine dust. Make sure you know the hazards associated with the type of dust you will be exposed to and always wear a respirator approved for that type of dust.



WARNING

Additional Safety Instructions for Metal Cutting Bandsaws

- 1. BLADE CONDITION.** Do not operate with dull, cracked or badly worn blade. Inspect blades for cracks and missing teeth before each use.
- 2. HAND PLACEMENT.** Never position fingers or thumbs in line with the cut. Hands could be crushed in vise or by falling machine components or cut by the blade.
- 3. ENTANGLEMENT HAZARDS.** Do not operate this bandsaw without blade guard in place. Otherwise, loose clothing, jewelry, long hair and work gloves can be drawn into working parts.
- 4. BLADE REPLACEMENT.** When replacing blades, make sure teeth face toward the workpiece. Wear gloves to protect hands and safety glasses to protect eyes.
- 5. WORKPIECE HANDLING.** Always support the workpiece with table, vise, or other support fixture. Flag long pieces to avoid a tripping hazard. Never hold the workpiece with your hands during a cut.
- 6. LOSS OF STABILITY.** Unsupported workpieces may jeopardize machine stability and cause the machine to tip and fall, which could cause serious injury.
- 7. POWER INTERRUPTION.** Unplug machine after power interruption. Machines without magnetic switches can start up after power is restored.
- 8. FIRE HAZARD.** Use EXTREME CAUTION if cutting magnesium. Using the wrong cutting fluid will lead to chip fire and possible explosion.
- 9. CUTTING FLUID SAFETY.** Always follow manufacturer's cutting fluid safety instructions. Pay particular attention to contact, contamination, inhalation, storage and disposal warnings. Spilled cutting fluid is a slipping hazard and a toxicity hazard.
- 10. ATTENTION TO WORK AREA.** Never leave a machine running and unattended. Pay attention to the actions of others in the area to avoid unintended accidents.
- 11. MAINTENANCE/SERVICE.** All inspections, adjustments, and maintenance are to be done with the machine **OFF** and the power disconnected to the machine. Wait for all moving parts to come to a complete stop.
- 12. HEARING PROTECTION & HAZARDS.** Noise generated by blade and workpiece vibration, material handling, and power transmission can cause permanent hearing loss over time and interfere with communication and audible signals. Always wear hearing protection.
- 13. HOT SURFACES.** Due to friction, the workpiece, chips, and some machine components can be hot enough to burn you.

WARNING

No list of safety guidelines can be complete. Every shop environment is different. Like all machines there is danger associated with the Model G9744Z. Accidents are frequently caused by lack of familiarity or failure to pay attention. Use this machine with respect and caution to lessen the possibility of operator injury. If normal safety precautions are overlooked or ignored, serious personal injury may occur.



SECTION 2: CIRCUIT REQUIREMENTS

220V Single-Phase

!WARNING

Serious personal injury could occur if you connect the machine to the power source before you have completed the setup process. **DO NOT** connect the machine to the power source until instructed to do so.

Amperage Draw

The Model G9744Z motor draws the following amps under maximum load:

Motor Draw at 220V 15 Amps

Circuit Requirements

We recommend using a dedicated circuit for this machine. You **MUST** connect your machine to a grounded circuit that is rated for the amperage given below. Never replace a circuit breaker on an existing circuit with one of higher amperage without consulting a qualified electrician to ensure compliance with wiring codes. **If you are unsure about the wiring codes in your area or you plan to connect your machine to a shared circuit, consult a qualified electrician.**

220V Circuit..... 20 Amps

Plug/Receptacle Type

Recommended Plug/Receptacle....NEMA L6-20

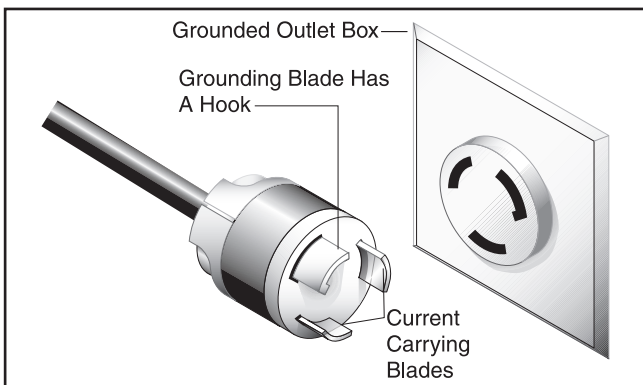
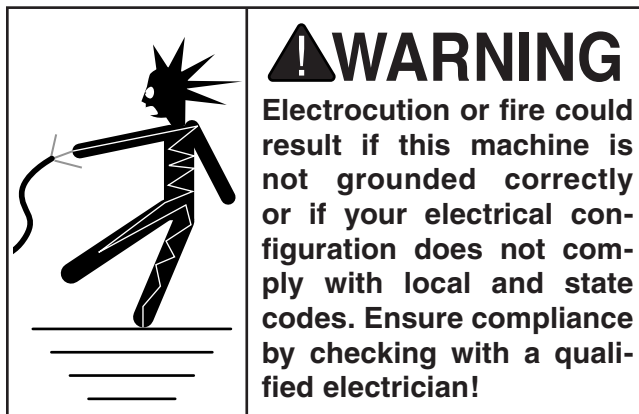

Figure 3. NEMA L6-20 plug and receptacle.

Grounding

In the event of an electrical short, grounding reduces the risk of electric shock. The grounding wire in the power cord must be properly connected to the grounding prong on the plug; likewise, the outlet must be properly installed and grounded. All electrical connections must be made in accordance with local codes and ordinances.



Extension Cords

We do not recommend the use of extension cords. Instead, arrange the placement of your equipment and the installed wiring to eliminate the need for extension cords.

If you find it absolutely necessary to use an extension cord at 220V with your machine:

- Use at least a 12 gauge cord that does not exceed 50 feet in length!
- The extension cord must also contain a ground wire and plug pin.
- A qualified electrician **MUST** size cords over 50 feet long to prevent motor damage.



SECTION 3: SETUP

Setup Safety

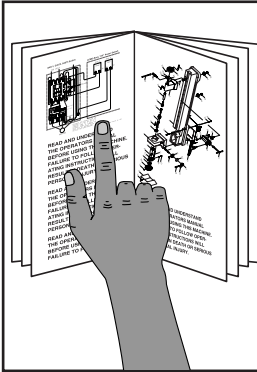

!WARNING
This machine presents serious injury hazards to untrained users. Read through this entire manual to become familiar with the controls and operations before starting the machine!

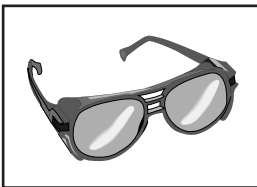

!WARNING
Wear safety glasses during the entire setup process!

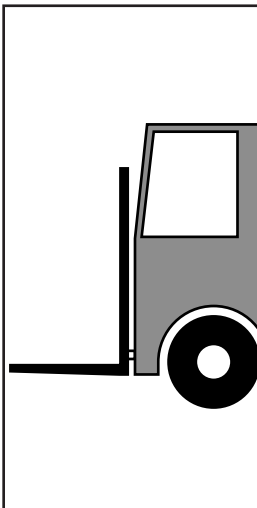

!WARNING
The Model G9744Z is an extremely heavy machine. Serious personal injury may occur if safe moving methods are not followed. To be safe, you will need assistance and power equipment when moving the shipping crate and removing the machine from the crate.

Items Needed for Setup

The following items are needed to complete the setup process, but are not included with your machine:

Description	Qty
• Safety Glasses (for each person)	1
• Solvent Cleaner.....	1
• Shop Towels.....	1
• Mounting Hardware (optional).....	1
• Forklift or Hoist	1
• Assistant.....	1
• Wrench 12mm.....	1

Unpacking

The Model G9744Z was carefully packed when it left our warehouse. If you discover the machine is damaged after you have signed for delivery, *please immediately call Customer Service at (570) 546-9663 for advice.*

Save the containers and all packing materials for possible inspection by the carrier or its agent. *Otherwise, filing a freight claim can be difficult.*

When you are completely satisfied with the condition of your shipment, you should inventory the contents.



Inventory

After all the parts have been removed from the crate, you should have the following items:

Box 1: (Figure 4) Qty

A. Model G9744Z Bandsaw 1

Hardware and Tools (Not Shown)

- Chip Tray 1
- Triangle Screw 5/16-18 x 3/4" 1
- Flat Washer 5/16" 1
- Hex Nut 5/16-18 1
- Hex Bolts M12-1.75 x 50 (Leveling) 4
- Hex Nuts M12-1.75 (Leveling) 4
- Handwheel 1
- Handwheel Handle 1

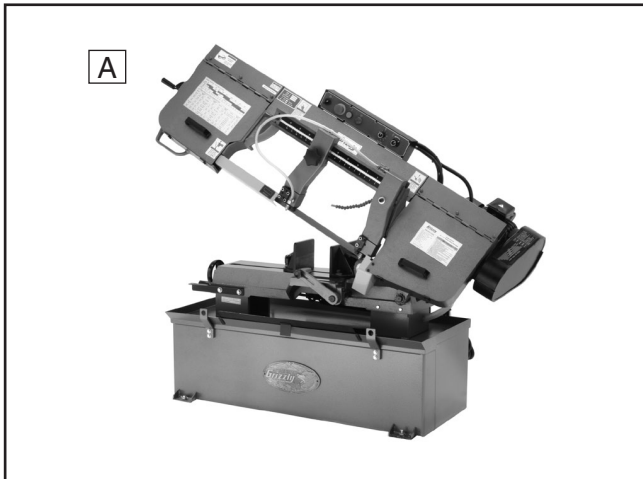

Figure 4. G9744Z inventory.

In the event that any nonproprietary parts are missing (e.g. a nut or a washer), we would be glad to replace them, or for the sake of expediency, replacements can be obtained at your local hardware store.

NOTICE

Some hardware/fasteners on the inventory list may arrive pre-installed on the machine. Check these locations before assuming that any items from the inventory list are missing.



Hardware Recognition Chart

USE THIS CHART TO MATCH UP
HARDWARE DURING THE ASSEMBLY
PROCESS!

MEASURE BOLT DIAMETER BY PLACING INSIDE CIRCLE

- #10
- 1/4"
- 5/16"
- 3/8"
- 7/16"
- 1/2"

- 4mm
- 6mm
- 8mm
- 10mm
- 12mm
- 16mm

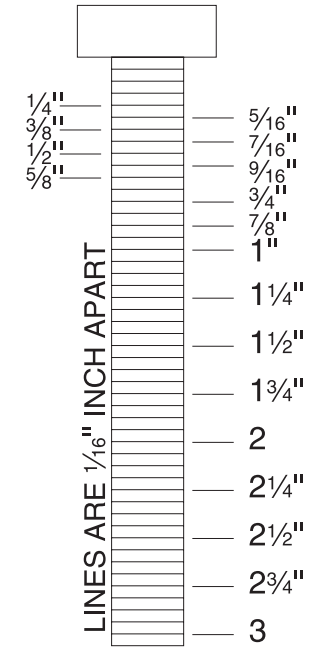
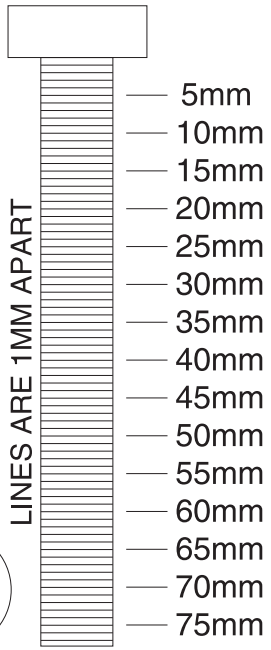
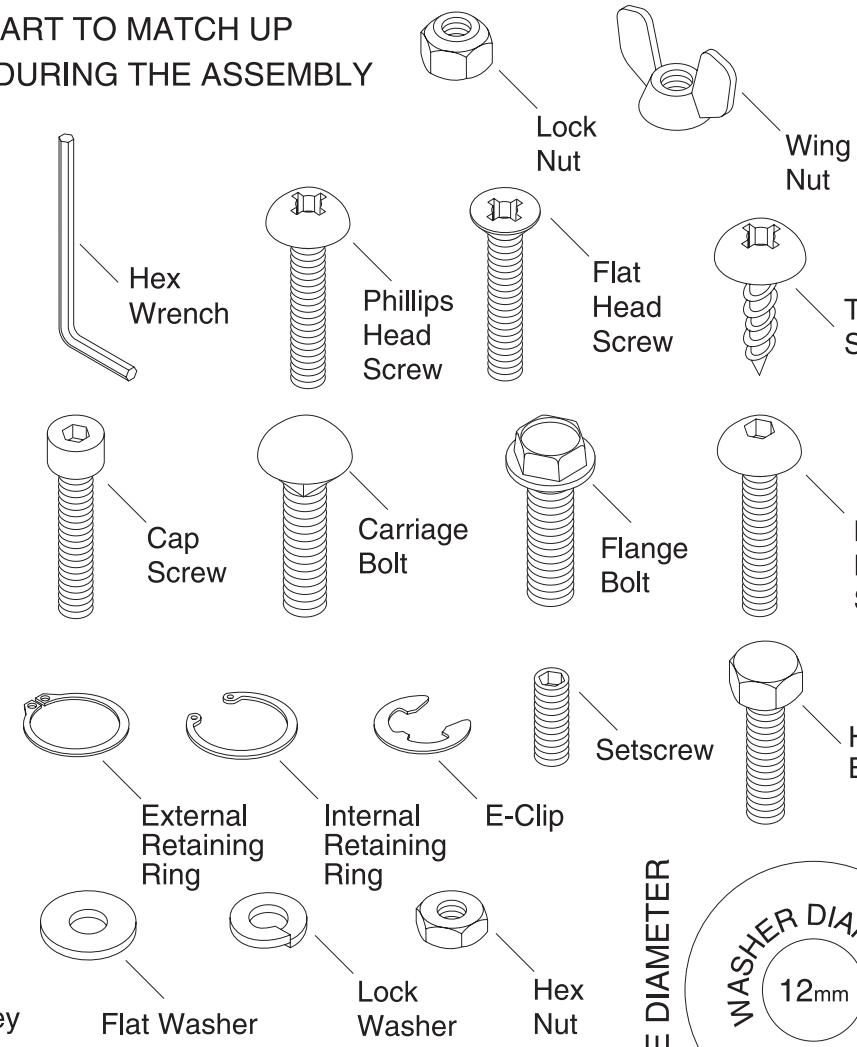

WASHERS ARE MEASURED BY THE INSIDE DIAMETER

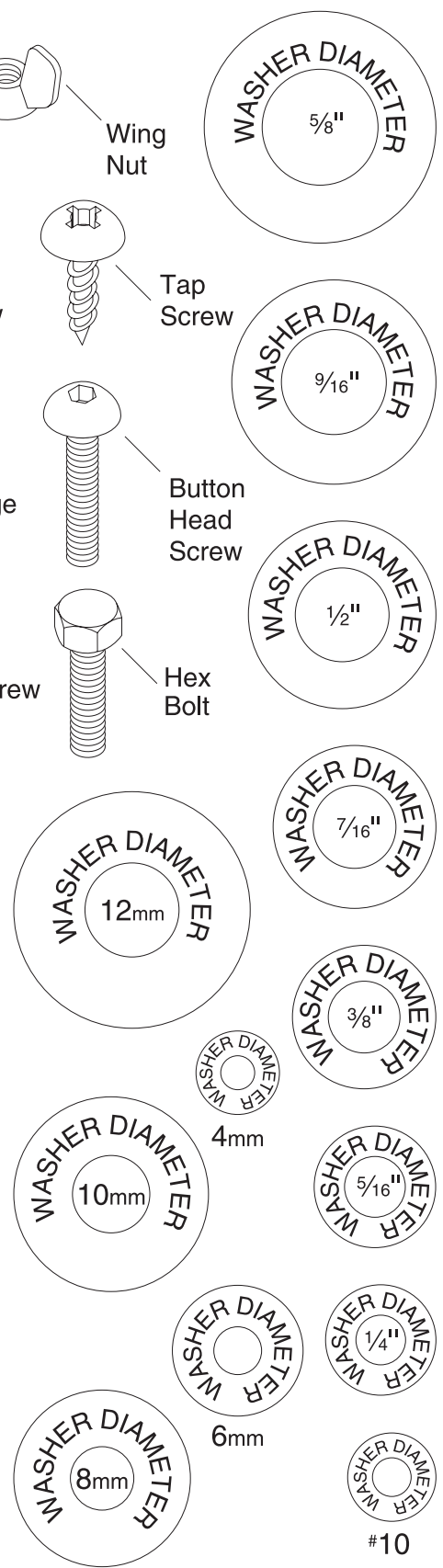

Clean Up

The unpainted surfaces are coated with a waxy oil to protect them from corrosion during shipment. Remove this protective coating with a solvent cleaner or citrus-based degreaser such as Grizzly's G7895 Degreaser. To clean thoroughly, some parts may need to be removed. **For optimum performance from your machine, make sure you clean all moving parts or sliding contact surfaces that are coated.** Avoid chlorine-based solvents, such as acetone or brake parts cleaner, as they will damage painted surfaces should they come in contact. Always follow the manufacturer's instructions when using any type of cleaning product.

	<p>⚠️ WARNING Gasoline and petroleum products have low flash points and could cause an explosion or fire if used to clean machinery. DO NOT use gasoline or petroleum products to clean the machinery.</p>
--	--

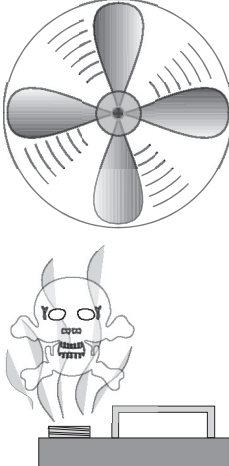
	<p>⚠️ CAUTION Many of the solvents commonly used to clean machinery can be toxic when inhaled or ingested. Lack of ventilation while using these solvents could cause serious personal health risks or fire. Take precautions from this hazard by only using cleaning solvents in a well ventilated area.</p>
---	--

Site Considerations

Floor Load

Refer to the **Machine Data Sheet** for the weight and footprint specifications of your machine. Some floors may require additional reinforcement to support both the machine and operator.

Machine Placement

Consider existing and anticipated needs, size of material to be processed through each machine, and space for auxiliary stands, work tables or other machinery when establishing a location for your new machine. See **Figure 5** for the minimum working clearances.

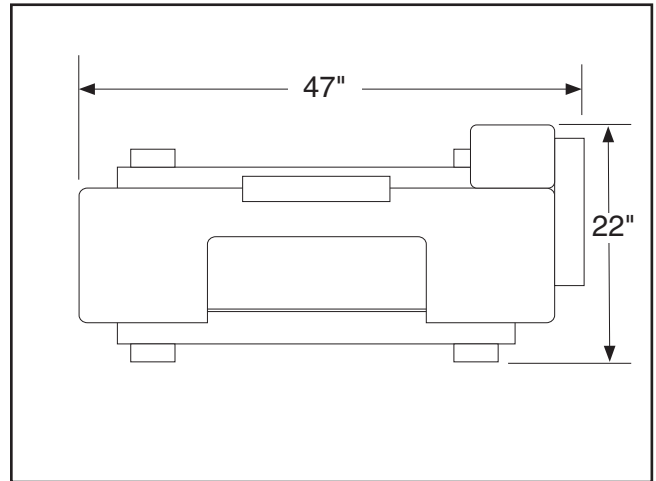
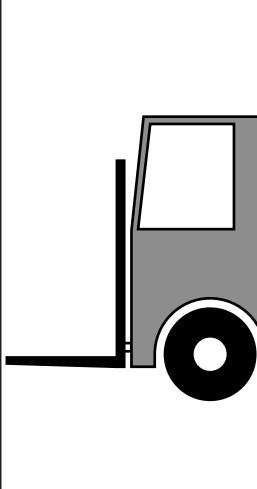

Figure 5. Minimum working clearances.

	<p>⚠️ CAUTION Unsupervised children and visitors inside your shop could cause serious personal injury to themselves. Lock all entrances to the shop when you are away and DO NOT allow unsupervised children or visitors in your shop at any time!</p>
--	--



Moving & Placing Base Unit



! WARNING
The Model G9744Z is an extremely heavy machine. Serious personal injury may occur if safe moving methods are not followed. To be safe, you will need assistance and power equipment when moving the shipping crate and removing the machine from the crate.

The Model G9744Z comes with lifting brackets installed on the base. Use a forklift and straps rated for the machine weight to lift the machine off the pallet and onto a suitable location (see **Figure 6**). The lifting brackets can be removed and saved for future use.

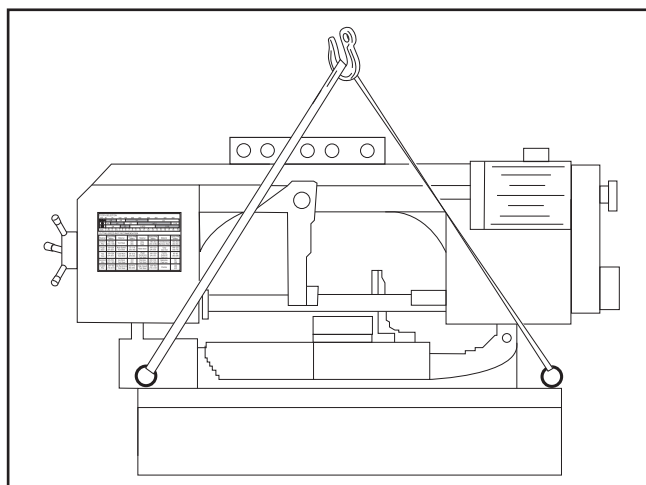

Figure 6. G9744Z lifting points.

Mounting to Shop Floor

Although not required, we recommend that you mount your new machine to the floor. Because this is an optional step and floor materials may vary, floor mounting hardware is not included. Generally, you can either bolt your machine to the floor or mount it on machine mounts. It will be necessary to level your machine after mounting. If you choose to set your machine on the floor, four M12-1.75 x 50 leveling bolts have been included.

Bolting to Concrete Floors

Lag shield anchors with lag bolts (**Figure 7**) and anchor studs are two popular methods for anchoring an object to a concrete floor.

NOTICE

Anchor studs are stronger and more permanent alternatives to lag shield anchors; however, they will stick out of the floor, which may cause a tripping hazard if you decide to move your machine.

Using Machine Mounts

Using machine mounts, shown in **Figure 7**, gives the advantage of fast leveling and vibration reduction. The large size of the foot pads distributes the weight of the machine.

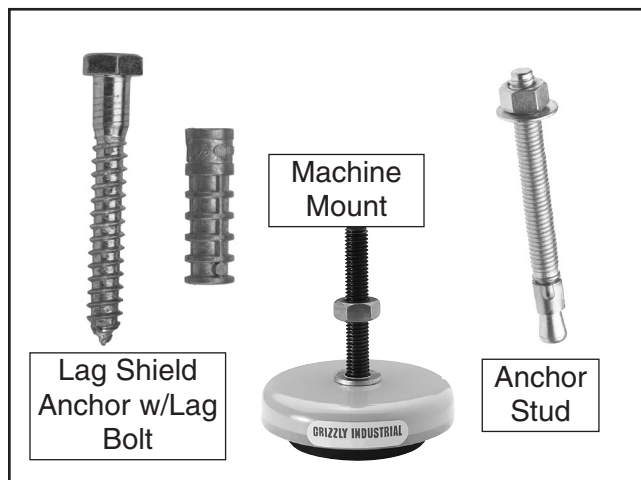

Figure 7. Typical options for machine mounting.



Shipping Bracket

A bracket has been installed to keep the saw in alignment during shipping. Before using your saw you will need to remove it. Store it for safe keeping in the event you move your saw to a different location.

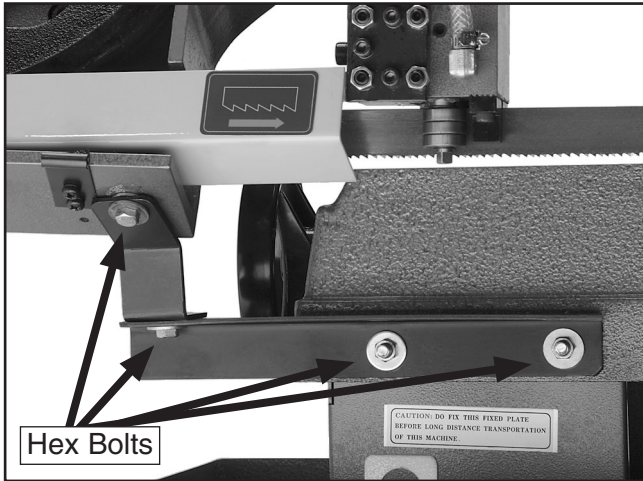

Figure 8. Shipping bracket.

To remove the shipping bracket:

1. Remove all four hex bolts shown in **Figure 8** with a 12mm wrench.

Workstop

The workstop is used when many cuts of the same length are needed (see **Figure 9**).

To setup the workstop:

1. Position the workstop rod the desired distance from the blade and tighten the cap screw to hold it in place.
2. Fine tune the measurement by adjusting the hex bolt and stop nut.
3. Swing the workstop arm down and out of the way when not in use.

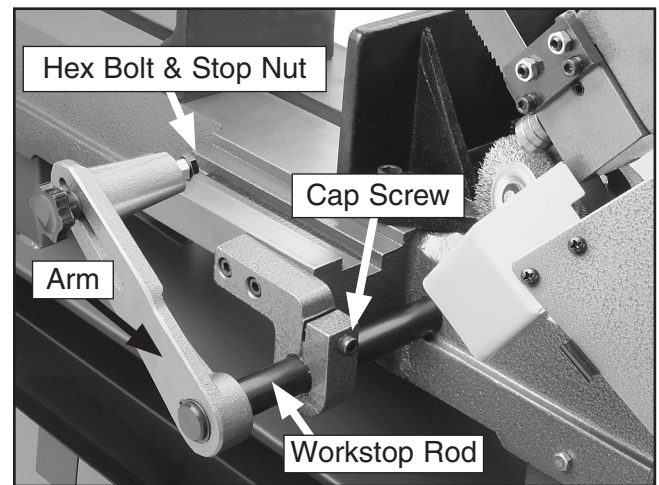

Figure 9. Workstop assembly.



Chip Tray

Components and Hardware Needed:	Qty
Chip Tray	1

The chip tray fits over the lip of the base as illustrated in **Figure 10**.

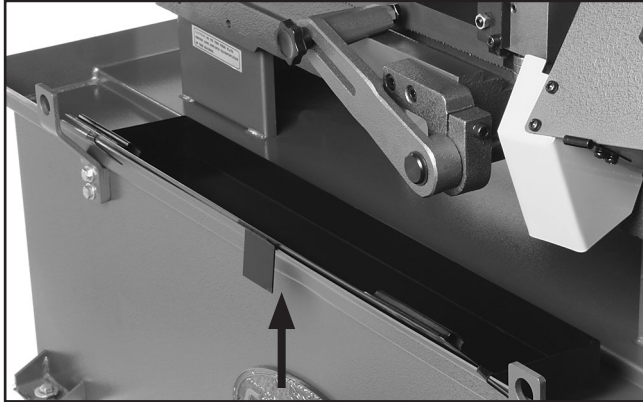

Figure 10. Chip tray installed.

Feed Stop

Depending on how the Model G9744Z was shipped, it may be necessary to adjust the feed stop before the test run. The blade should not make contact with any part of the vise assembly.

To adjust the feed stop bolt:

1. Adjust the feed stop bolt and jam nut (**Figure 11**), so the bandsaw blade teeth are just below the vise table surface when the cut is complete.

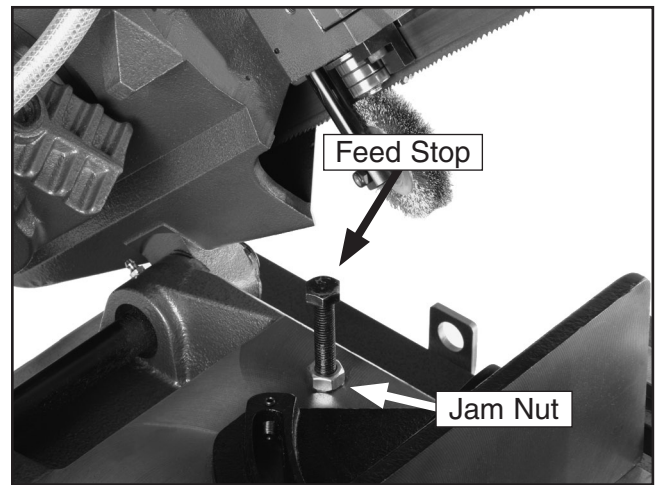

Figure 11. Feed stop.



Recommended Adjustments

The adjustments listed below have been performed at the factory. However, because of the many variables involved with shipping, we recommend that you at least verify the following adjustments to ensure accurate cutting results.

Step-by-step instructions on verifying these adjustments can be found in **SECTION 7: SERVICE ADJUSTMENTS**.

Factory adjustments that should be verified:

1. Blade Tracking (**Pages 35 & 36**).
2. Blade Guide Bearings (**Page 36**).

Test Run

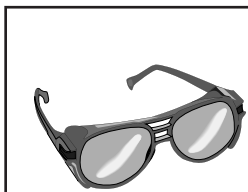

WARNING

Projectiles thrown from the machine could cause serious eye injury. Wear safety glasses during assembly and operation.

Complete this process once you have familiarized yourself with all instructions in this manual.

Starting the machine:

1. Read the entire instruction manual.
2. Make sure all tools and foreign objects have been removed from the machine.
3. Put on safety glasses and secure loose clothing or long hair.
4. Connect the bandsaw to power.
5. Raise the bandsaw and close the feed control knob to keep the saw in place (see **Figure 12**).

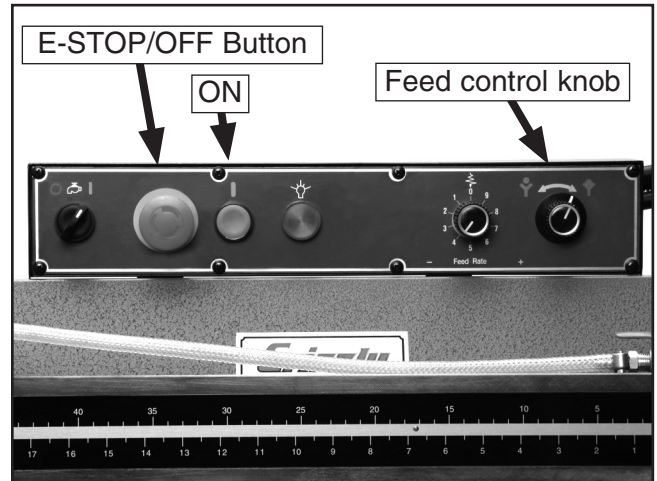

Figure 12. Control panel.

6. Start the bandsaw while keeping your finger near the EMERGENCY STOP/OFF button (**Figure 12**) at all times during the test run. The bandsaw should run smoothly with little or no vibration.

Note: If the EMERGENCY STOP/OFF button is pressed, it needs to be twisted until it pops out or the bandsaw will not start.

7. Push the emergency stop button. The blade should stop turning and the coolant pump should shut **OFF**.

—If you suspect any problems, immediately stop the bandsaw and correct before continuing.

—If you need any help with your bandsaw call our Tech Support at (570) 546-9663.

NOTICE

DO NOT operate saw without checking gear box oil level! Operating without sufficient oil will damage the machine.



SECTION 4: OPERATIONS

Operation Safety

⚠️ WARNING

Damage to your eyes, lungs, and ears could result from using this machine without proper protective gear. Always wear safety glasses, a respirator, and hearing protection when operating this machine.

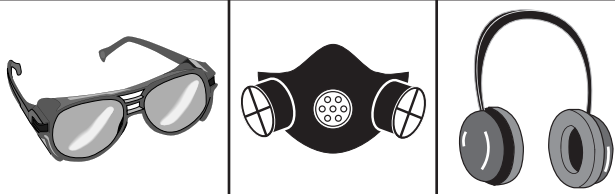

⚠️ WARNING

Loose hair and clothing could get caught in machinery and cause serious personal injury. Keep loose clothing and long hair away from moving machinery.

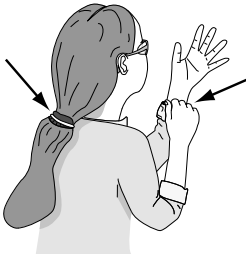

NOTICE

This bandsaw is for trained operators only. **WE STRONGLY RECOMMEND** that you read books, trade magazines, and get formal training before beginning any projects. Regardless of the content in this section, Grizzly Industrial will not be held liable for accidents caused by lack of training.

Vise

⚠️ CAUTION

Always turn the saw *OFF* and allow the blade to come to a complete stop before using the vise! Failure to follow this caution may lead to injury.

The vise has a quick release feature that allows jaw width to be quickly adjusted when changing from one sized material to another.

To rapidly change the vise jaw gap:

1. Turn the handwheel counterclockwise to relieve any pressure on the vise jaw.
2. Pull or push the jaw in the desired direction.
3. Finish tightening the jaw against the workpiece with the handwheel.

Note: *Figure 13* shows correct methods of holding different workpiece shapes.

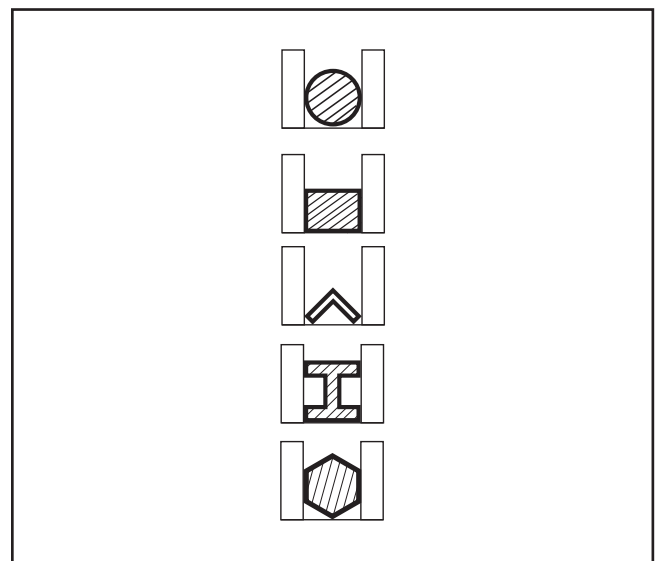

Figure 13. Workholding options by material shape.



The vise can be adjusted to cut any angle from a straight 90 degree cut-off, to a 45 degree angle by loosening the two vise lock handles. Positive stops at 90° and 45° allow you to quickly return the rear jaw to either angle. Angles between 90° and 45° can be read using the scale on the side of the vise table. Use a combination square or bevel protractor if higher precision is required when finding these angles.

To adjust the positive stops:

1. Check the current vise jaw-to-blade angle with a machinist square (see **Figure 14**).

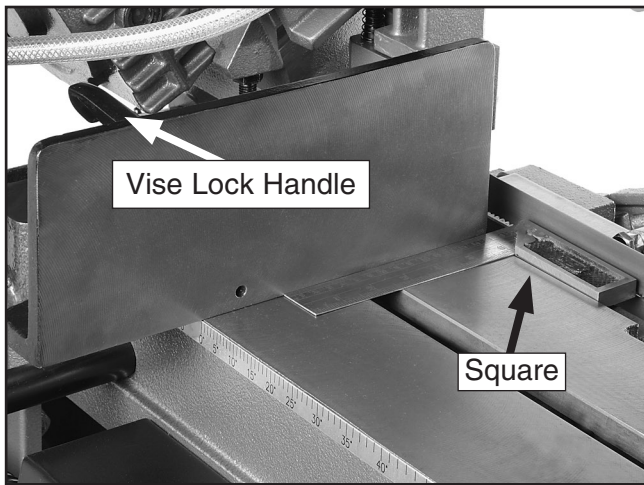

Figure 14. Squaring vise to blade.

2. If the angle is not 90°, loosen the vise lock handle then adjust the set screw as needed to set the positive stop to 90° (see **Figure 15**).

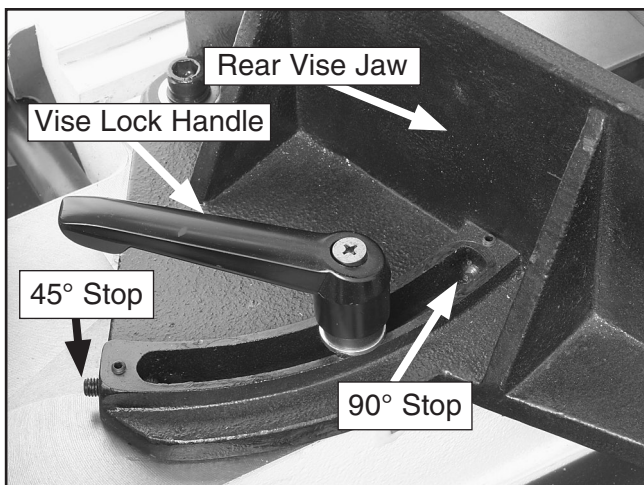

Figure 15. Positive stop adjustments.

3. With the rear vise jaw making contact with the positive stop, tighten the rear vise jaw and re-check the angle.
4. Loosen the rear vise lock handle and swing the rear jaw until it reaches the 45° positive stop.
5. Tighten the rear jaw and check the angle.
6. If the angle is not at 45°, loosen the vise jaw and adjust the set screw as needed to set the positive stop to 45°.
7. With the rear vise jaw making contact with the positive stop, tighten the rear vise jaw and re-check the angle.

For setting angles between the stops (45°–90°):

1. To find your angle, use the scale on the side of the vise or use a combination square or bevel protractor for more precise measurements.
2. Adjust and lock the rear vise jaw to your chosen angle.
3. After the final angle has been chosen, loosen the lock handle in **Figure 16** on the opposite jaw so the jaw can float, and match the angle of the workpiece and rear jaw.

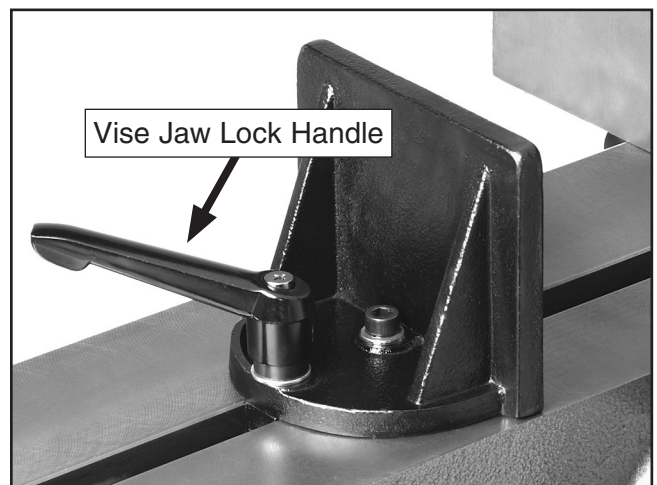

Figure 16. Front vise jaw lock handle.

4. Tighten the vise against the workpiece then tighten the jaw lock handle.



Blade Guide Arms

The blade guide bearings are mounted on the front and rear arms. The rear arm is adjustable and should be set as close to the workpiece as possible. This will help ensure straight cuts by keeping the blade from twisting and drifting off of the cut line.

To adjust the rear blade guide arm:

Loosen the knob shown in **Figure 17** and slide the rear blade guide as close to the workpiece as possible, then tighten the knob.

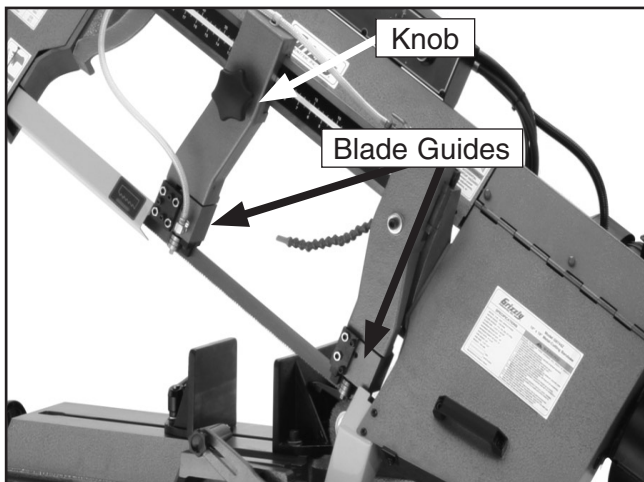

Figure 17. Blade guides.

The front blade guide arm has a self-adjusting wire brush that makes contact with the blade to help clear away chips and extend blade life (see **Figure 18**).

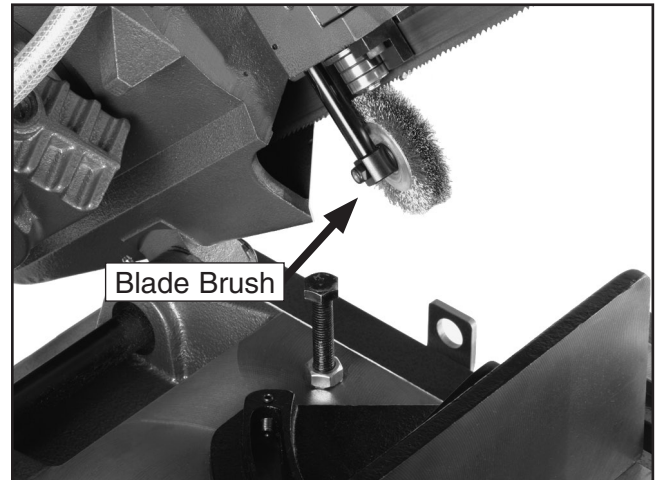

Figure 18. Blade brush.



Blade Selection

The Model G9744Z uses 129 $\frac{3}{8}$ " x 1" bandsaw blades.

Selecting the right blade for the job depends on a variety of factors, such as the type of material being cut, hardness of the material, material shape machine capability, and operator technique.

The chart below is a basic starting point for choosing blade type based on teeth per inch (TPI) for variable tooth pitch blades and for standard raker type bi-metal blades/HSS blades. However, for exact specifications of bandsaw blades, contact the blade manufacturer.

To select the correct blade TPI:

1. Measure the material thickness. This measurement is the length of cut taken from where the tooth enters the workpiece, sweeps through, and exits the workpiece.

2. Refer to the "Material Width/Diameter" row of the blade selection chart in **Figure 19** and read across to find your workpiece thickness you need to cut.
3. Refer to the "Material Shapes" row and find the shape and material to be cut.
4. In the applicable row, read across to the right and find the box where the row and column intersect. Listed in the box is the minimum TPI recommended for the variable tooth pitch blades.
5. The "Cutting Speed Rate Recommendation" section of the charts offers guidelines for various metals, given in feet per minute (speed FPM) and meters per minute in parenthesis.

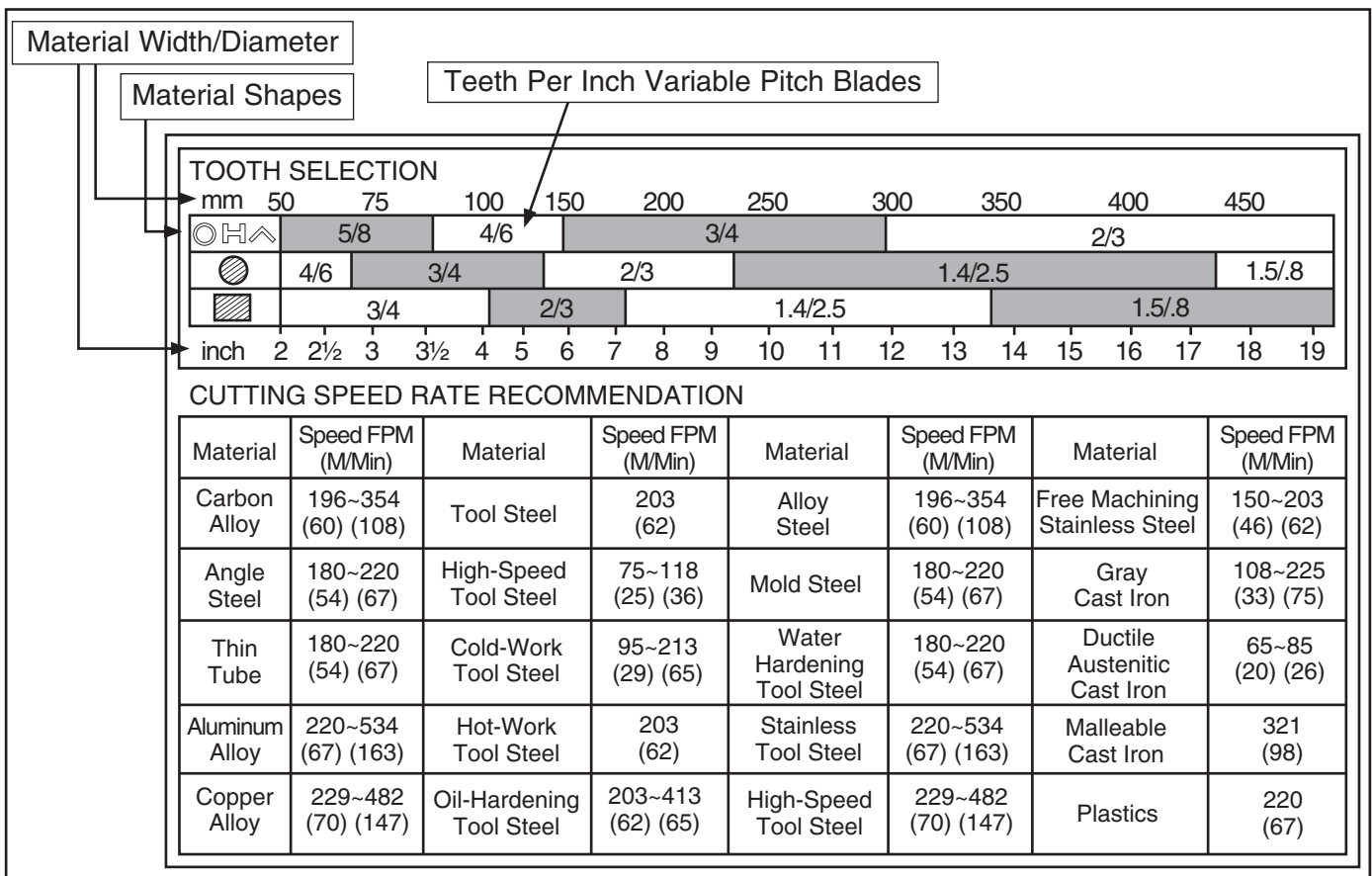

Figure 19. Model G9744Z blade selection and speed chart.



Blade Speed



! WARNING
Entanglement Hazard!
You MUST install the pulley cover before operating or severe injury may occur.

The Model G9744Z has four speed settings—114, 196, 288, and 377 feet per minute (FPM). Refer to the chart on **Page 23** for cutting speed recommendations by material type.

To change blade speeds:

1. UNPLUG THE BANDSAW!
2. Open the belt cover.
3. With one hand, support the weight of the motor. With the other hand, loosen the belt tension knob (see **Figure 20**). The motor will drop and the V-belt will slacken.

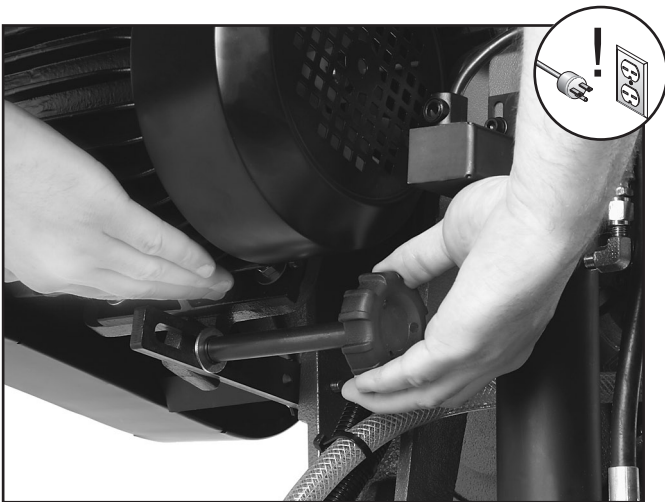

Figure 20. Belt tension knob.

4. Move the V-belt to the desired pulley combination (see **Figure 21**).

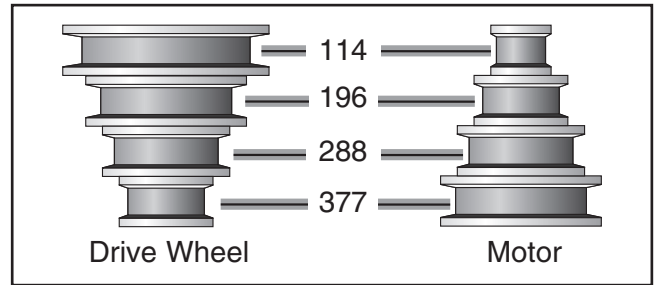

Figure 21. V-belt positions in FPM.

5. Lift the motor to tension the belt and tighten the belt tension knob.
6. Close the belt cover.

Feed Rate

The speed at which the saw blade will cut through a workpiece is controlled by blade type, feed rate, and feed pressure. The feed rate is controlled by two knobs on the control panel.

Note: *If a lubricant is used on the cut, the feed rate can be increased by approximately 15%.*

To set the feed rate:

1. Raise the bow to the highest position.
2. Set the "Feed Rate Dial" in **Figure 22** to the desired feed rate—0 (slowest), 9 (fastest).

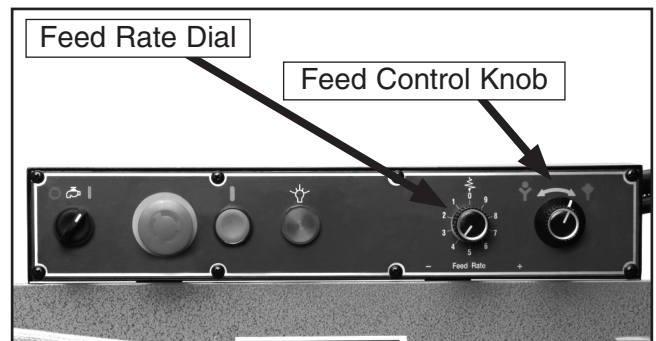

Figure 22. Feed rate controls.

3. Turn the feed control knob to the left to lower the bow at the feed rate you have set. Turning the knob to the right locks the bow in position.



Coolant System



This bandsaw has a built-in coolant system that extends the life of your bandsaw blades by lowering the temperature of the blade and workpiece when cutting.

See **Cutting Fluid** on **Page 26** for additional information.

To use the coolant system:

1. Access the reservoir by removing the rear panel on the base (see **Figure 23**).

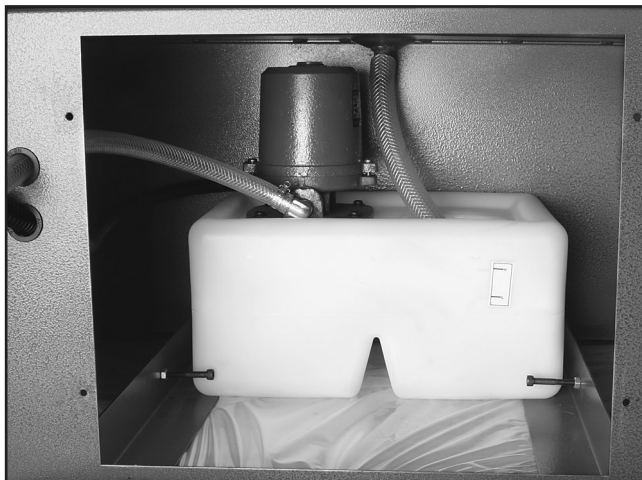

Figure 23. Coolant system reservoir and cover.

2. Thoroughly clean and remove any foreign material that may have fallen inside the reservoir during shipping.
3. Fill the reservoir with your chosen cutting fluid solution and replace the rear panel.
4. Make sure the coolant control valve is turned **OFF**.
5. Turn the coolant pump switch **ON** before making your cut.
6. Adjust the valve on the coolant hose to control the flow of coolant (see **Figure 24**). Make sure that the pressure is not so high that coolant spills on the floor and creates a slipping hazard.

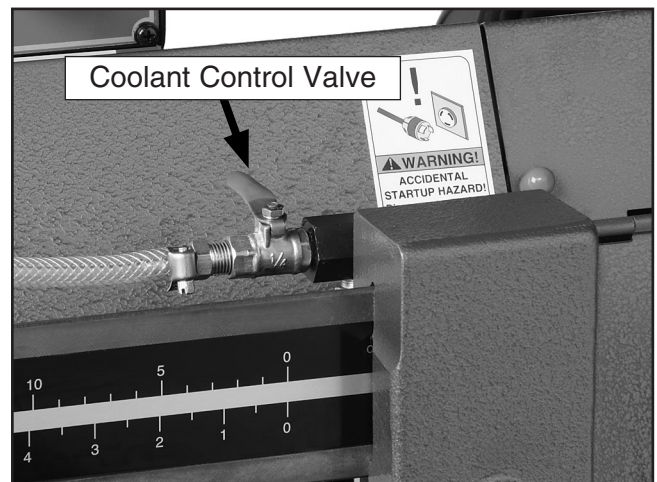

Figure 24. Coolant control valve.

7. When the bandsaw reaches the bottom of the cut, the motor and coolant system will shut **OFF**.

NOTICE

Keep the tray chip screen clear so coolant can recycle to the pump reservoir. **NEVER** operate the pump with the reservoir below the low mark or you will overheat the pump and void your warranty!



Cutting Fluid

	<p>!WARNING BIOLOGICAL AND POISON HAZARD! Use proper personal protection equipment when handling cutting fluid and follow federal, state, and fluid manufacturer requirements to properly dispose of cutting fluid.</p>
---	---

While simple in concept and function, many issues must be taken into account to find and use the correct cutting fluid. Always follow all product warnings and contact the fluid manufacturer for unanswered questions.

Use the selections below to choose the appropriate cutting fluids:

- For cutting low alloy, low carbon, and general-purpose category metals with a bi-metal blade—use a water soluble cutting fluid.
- For cutting stainless steels, high carbon, and high alloy metals, brass, copper and mild steels—use "Neat Cutting Oil" (commonly undiluted mineral oils) that have extreme pressure additives (EP additives).
- For cutting cast iron, cutting fluid is not recommended.

Remember: Too much flow at the cutting fluid nozzle will make a mess and can make the work area unsafe; and not enough fluid at the cut will heat the blade, causing the blade teeth to load up and break.

Adjust the flow rate lever so the coolant will cool and lubricate the blade, and flush the chips away so they do not stick to the blade. If the chips build up on the blade, eventually they will bind and skid in the next cut, breaking blade teeth, and damaging the bandsaw wheels.

<p>!WARNING BIOLOGICAL and POISON HAZARD!</p> 	
--	--

The reservoir on this machine is designed to store cutting fluid. During storage some fluids grow dangerous microbes, or due to the collection of toxic metal chips in the fluid, the fluid can become a potent and extremely poisonous solution to humans and animals.

USE the correct personal protection equipment when handling cutting fluids to prevent infections and poisoning.

USE a good bactericide and fungicide for additional protection.

FOLLOW federal, state, and the fluid manufacturer requirements to properly dispose of cutting fluid when it becomes unsafe.

<p><i>NOTICE</i></p> <p>Clean coolant system with a bactericide and fungicide between coolant changes to prevent recontamination.</p>



You need to change coolant when you notice the following conditions:

- Low sump level
- Abnormal appearance (change in fluid color)
- Foul smell (rancidity)
- Floating matter on the fluid (chips, swarf, mold)
- Tramp oil floating on the surface (leaking machine and hydraulic oils)
- Excessive foam (improper mixture, too high of pressure, excessive air in system)
- Dirty machine or trenches (cleaners in the fluid have become depleted)
- User notices skin irritation
- User has respiratory irritation
- Other problems that might be fluid related are:
 - rust on machine or part
 - staining on machine or part
 - tool failure due to loss of coolant performance
 - growth of fungi that would block coolant flow
 - change in coolant viscosity (thicker or thinner)
 - accumulation of water at the bottom of the sump in straight oils
 - dirt and grit suspended in coolant
 - general loss of performance (burning part or tool)

Consult your coolant manufacturer and MSDS for complete use and disposal information.

Operation Tips

The following tips will help you safely and effectively operate your bandsaw, and help you get the maximum life out of your saw blades.

Tips for horizontal cutting:

- Use the work stop to quickly and accurately cut multiple pieces of stock to the same length.
- Clamp the material firmly in the vise jaws to ensure a straight cut through the material, and use the positive lock to speed production.
- Let the blade reach full speed before engaging the workpiece.
- Never start a cut with the blade in contact with the workpiece, and do not start a cut on a sharp edge.
- Chips should be curled and silvery. If the chips are thin and powder like, increase your feed rate.
- Burned chips indicate a need to reduce your blade speed.
- Wait until the blade has completely stopped before removing the workpiece from the vise, and avoid touching the cut end—it could be very hot!
- Support long pieces so they won't fall when cut, and flag the ends to alert passers-by of potential danger.
- Adjust the blade guides as close as possible to the workpiece to minimize side-to-side blade movement.
- Use coolant when possible to increase blade life.

NOTICE

Loosen blade tension at the end of each day to prolong blade life.



SECTION 5: ACCESSORIES

Tool Steel Blades

G6432—129³/₈ x 1 x .032 10 TPI Raker

G6433—129³/₈ x 1 x .032 14 TPI Raker

Variable Pitch Bi-Metal Blades

G6434—129³/₈ x 1 x .032 3-4 Variable Pitch

G6435—129³/₈ x 1 x .032 4-6 Variable Pitch

G6436—129³/₈ x 1 x .032 5-8 Variable Pitch

G6437—129³/₈ x 1 x .032 6-10 Variable Pitch

G6438—129³/₈ x 1 x .032 8-12 Variable Pitch

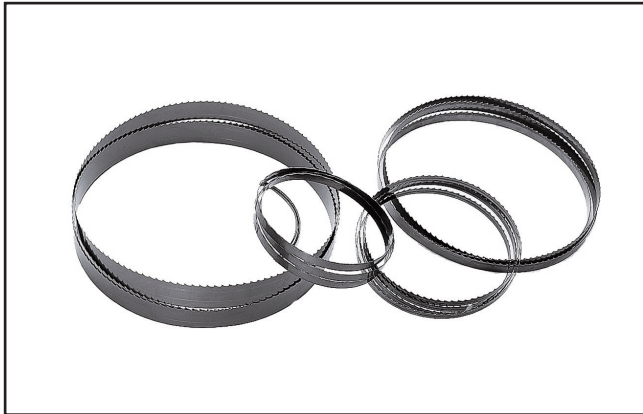

Figure 25. Blades.

H5408—Blade Tensioning Gauge

The Blade Tensioning Gauge ensures long blade life, reduced blade breakage, and straight cutting by indicating correct tension. A precision dial indicator provides you with a direct readout in PSI.



Figure 26. H5408 Blade Tensioning Gauge.

H5405—Lenox® Lube Tube™

Lenox® Lube Tube™ is a stick lubricant designed to prevent heat buildup. Apply it directly to the blade to improve overall blade life and productivity. Can be used on ferrous and non-ferrous metals. Biodegradable, non-toxic, and non-staining 14.5 oz tube.



Figure 27. Lenox® Lube Tube™.

G7897—Machining Fluid

This biostable, soluble oil for heavy-duty machining applications provides stable pH performance, which resists bacteria, fungal growth, rancidity and odors. Can be used in light or heavy machining. Mix with water, 1:21 for general use or 1:11-1:16 for heavy use.



Figure 28. G7897 Machining Fluid.

Call 1-800-523-4777 To Order



G5618—Deburring Tool with Two Blades

G5619—Extra Aluminum Blades

G5620—Extra Brass and Cast Iron Blade

The quickest tool for smoothing freshly machined metal edges. Comes with two blades—one for steel/aluminum and one for brass/cast iron.



Figure 29. G5618 Deburring Tool.

H1302—Standard Earmuffs

H4979—Deluxe Twin Cup Hearing Protector

H4977—Work-Tunes Radio Headset Earmuffs

Protect yourself comfortably with a pair of cushioned earmuffs. Especially important if you or employees operate for hours at a time.



Figure 31. Our most popular earmuffs.

G7984—Face Shield

H1298—Dust Sealed Safety Glasses

H1300—UV Blocking, Clear Safety Glasses

H2347—Uvex® Spitfire Safety Glasses

H0736—Shop Fox® Safety Glasses

Safety Glasses are essential to every shop. If you already have a pair, buy extras for visitors or employees. You can't be too careful when it comes to shop safety!

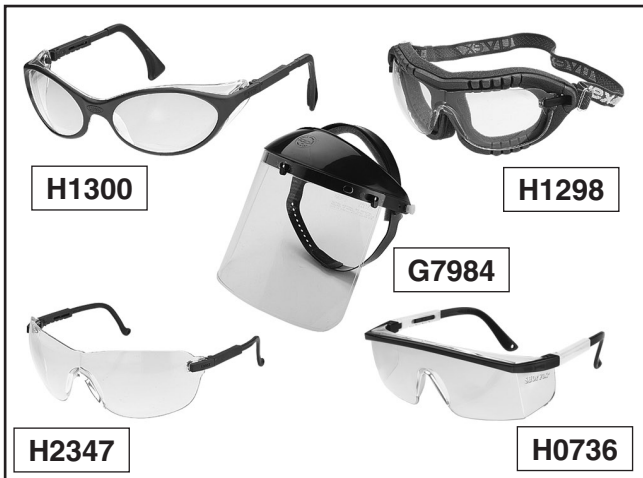

Figure 30. Our most popular safety glasses.

G9256—6" Dial Caliper

G9257—8" Dial Caliper

G9258—12" Dial Caliper

These traditional dial calipers are accurate to 0.001" and can measure outside surfaces, inside surfaces, and heights/depths. Features stainless steel, shock resistant construction and a dust proof display.

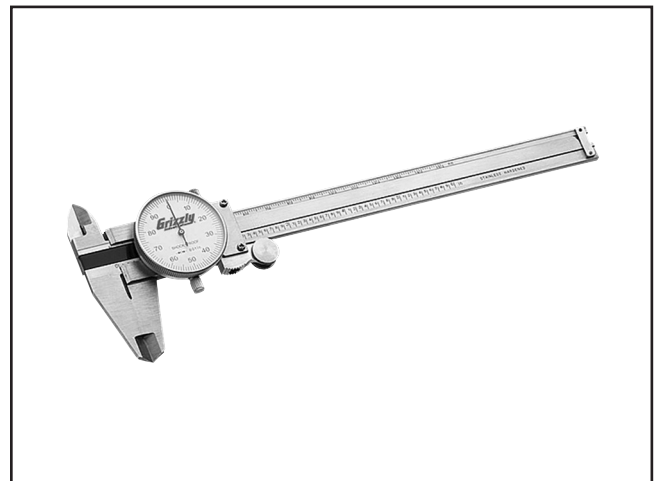
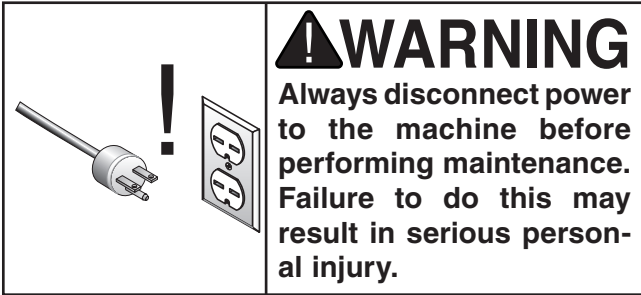

Figure 32. Grizzly® Dial Calipers.

Call 1-800-523-4777 To Order



SECTION 6: MAINTENANCE



Schedule

For optimum performance from your machine, follow this maintenance schedule and refer to any specific instructions given in this section.

Daily Check:

- Loose mounting bolts.
- Damaged saw blade.
- Worn or damaged wires.
- Any other unsafe condition.
- Clean after each use.
- Proper blade tension.
- Coolant level.
- Coolant condition.

Monthly Check:

- Lubricate vise screw.
- Check gear box fluid level.

Annual Check:

- Change gear box oil (every four months if being used daily).

Cleaning

Cleaning the Model G9744Z is relatively easy. After using your bandsaw, remove excess chips by sweeping. Then remove chips for recycling.

Wipe down the machine and remove any standing coolant.

Lubrication

Since all bearings are sealed and permanently lubricated, leave them alone until they need to be replaced. Do not lubricate them. However, you must periodically lubricate threaded adjustment locations and check the gear box oil level.

Lubricate the following areas as follows:

- **Blade Tension Mechanism:** Open the main blade guard and drop a few drops of oil on the tension knob lead screw (see **Figure 33**).

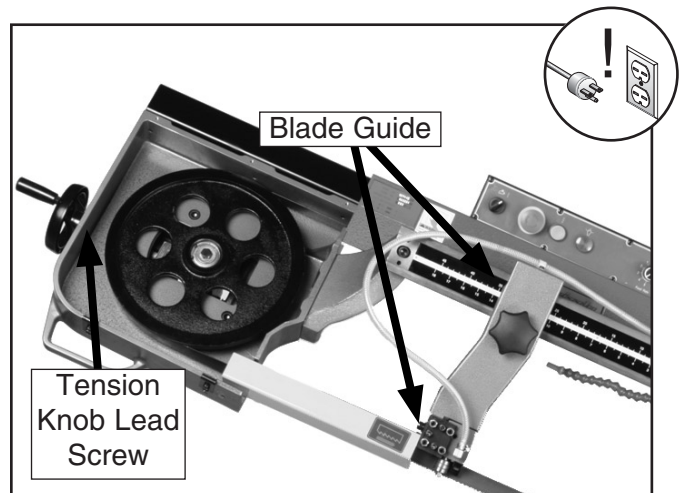

Figure 33. Main lubrication points.



- **Blade and Guides:** Drop a few drops of light machine oil on the blade and the blade guides daily, especially when cutting cast iron, as no cutting fluid is recommended (see **Figure 33**).
- **Table and Machined Surfaces:** Tables can be kept rust-free with regular applications of products like SLIPIT®. For long term storage you may want to consider products like Boeshield T-9™.
- **Vise Leadscrew:** Place a few drops of light machine oil on the vise leadscrew weekly (see **Figure 34**).

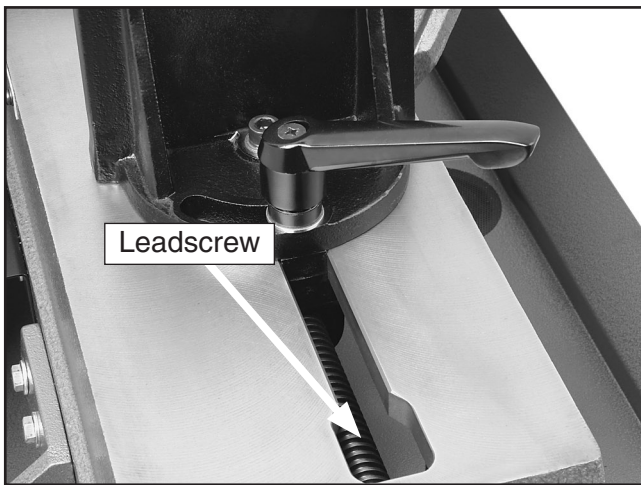

Figure 34. Vise leadscrew lubrication area.

- **Grease Fittings on Pivot Point:** Grease these with general purpose grease as needed to keep the pivot moving freely (see **Figure 35**).

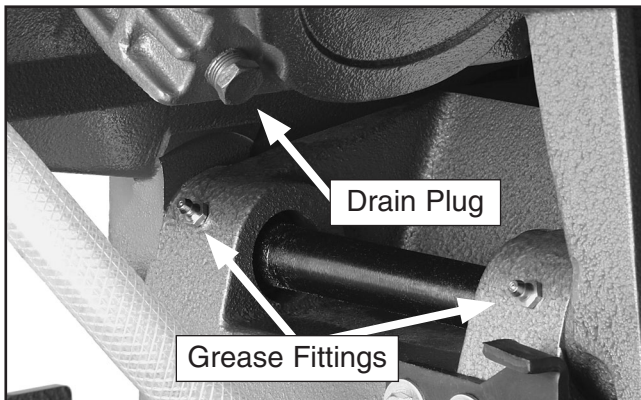

Figure 35. Lubrication points.

The gearbox should be drained and refilled after the first 50 hours of use and then once every year. Use a high quality, ISO 68 or SAE 90 gear oil.

To change the gear oil:

1. Run the bandsaw for a couple of minutes to warm up the oil in the gearbox.
2. UNPLUG THE BANDSAW!
3. Raise the bow to the highest angle and close the feed control knob to lock the bow in position.
4. Drain the gearbox by removing the drain plug shown in **Figure 35**.
5. Replace the drain plug, then lower the bow to its lowest position.
6. Open the fill cap and fill the gearbox with oil until you see the oil level reach the halfway point in the sight glass (see **Figure 36**).

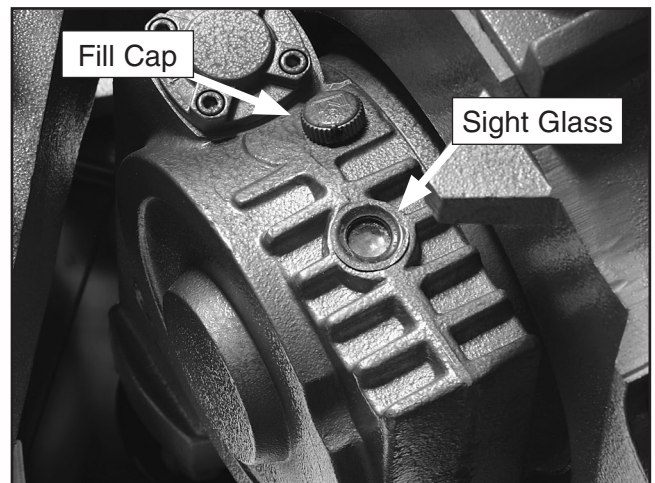

Figure 36. Gear box.

7. Tighten the fill plug, connect the machine to power and run the saw for a minute or two, then check the oil level. Add more oil if needed to maintain the level at the halfway mark in the sight glass.



SECTION 7: SERVICE

Review the troubleshooting and procedures in this section to fix your machine if a problem develops. If you need replacement parts or you are unsure of your repair skills, then feel free to call our Technical Support at (570) 546-9663.

Troubleshooting



Motor & Electrical

SYMPTOM	POSSIBLE CAUSE	CORRECTIVE ACTION
Machine does not start or a breaker trips.	<ol style="list-style-type: none"> Emergency-Stop button pressed. Plug/receptacle is at fault or wired incorrectly. Start capacitor is at fault. Wall fuse/circuit breaker is blown/tripped. Motor connection wired incorrectly. Power supply is at fault/switched OFF. Motor ON/OFF switch is at fault. Wiring is open/has high resistance. Motor is at fault. 	<ol style="list-style-type: none"> Twist Emergency-Stop button until it pops out. Test for good contacts; correct the wiring. Test/replace capacitor if faulty. Ensure correct size for machine load; replace weak breaker. Correct motor wiring connections. Ensure hot lines have correct voltage on all legs and main power supply is switched ON. Replace faulty ON/OFF switch. Check for broken wires or disconnected/corroded connections, and repair/replace as necessary. Test/repair/replace.
Machine stalls or is under-powered.	<ol style="list-style-type: none"> Wrong blade for the workpiece material. Wrong workpiece material. Feed rate/cutting speed too fast for task. Blade is slipping on wheels. Low power supply voltage. Motor bearings are at fault. Plug/receptacle is at fault. Motor connection is wired incorrectly. Motor has overheated. Motor is at fault. 	<ol style="list-style-type: none"> Use blade with correct properties for your type of cutting. Use metal with correct properties for your type of cutting. Decrease feed rate/cutting speed. Adjust blade tracking and tension. Ensure hot lines have correct voltage on all legs. Test by rotating shaft; rotational grinding/loose shaft requires bearing replacement. Test for good contacts; correct the wiring. Correct motor wiring connections. Clean off motor, let cool, and reduce workload. Test/repair/replace.
Machine has vibration or noisy operation.	<ol style="list-style-type: none"> Motor fan is rubbing on fan cover. Blade is at fault. Gearbox is at fault. Wrong blade for material. Speed is set too slow. 	<ol style="list-style-type: none"> Replace dented fan cover; replace loose/damaged fan. Replace/resharpen blade. Rebuild gearbox for bad gear(s)/bearing(s). Change blade. Adjust speed as required.



Bandsaw Operations



SYMPTOM	POSSIBLE CAUSE	CORRECTIVE ACTION
Machine is loud when cutting or bogs down in the cut.	<ol style="list-style-type: none"> Excessive feed rate. The blade TPI is too great, or the material is too coarse. 	<ol style="list-style-type: none"> Refer to Feed Rate on Page 24, or Blade Speed on Page 24 and adjust as required. Refer to Blade Selection on Page 23 and adjust as required.
Blades break often.	<ol style="list-style-type: none"> Blade is not tensioned correctly. The workpiece is loose in the vise. The feed or cut speed is wrong. The blade TPI is too great, or the material is too coarse. The blade is rubbing on the wheel flange. The bandsaw is being started with the blade resting on the workpiece. The guide bearings are misaligned, too tight, or the blade is rubbing on the wheel flange. The blade is too thick, or the blades are of low quality. 	<ol style="list-style-type: none"> Check to see that blade is not excessively tight or too loose. Clamp the workpiece tighter, or use a jig to hold the workpiece. Refer to Feed Rate on Page 24, or Blade Speed on Page 24 and adjust as required. Refer to Blade Selection on Page 23, and adjust as required. Refer to Blade Tracking on Page 36, and adjust as required. Start bandsaw and then slowly lower the headstock by setting the feed rate. Refer to Blade Tracking on Page 36, or Blade Guide Arms on Page 22, and adjust as required. Use a higher quality blade.
Blade dulls prematurely.	<ol style="list-style-type: none"> The cutting speed is too fast. The blade TPI is too coarse. The blade feed pressure is too light. The workpiece has hard spots, welds, or scale is on the material. The blade is twisted. The blade is slipping on the wheels. 	<ol style="list-style-type: none"> Refer to Blade Speed on Page 24 and adjust as required. Refer to Blade Selection on Page 23, and adjust as required. Refer to Feed Rate on Page 24, and adjust as required. Increase the feed pressure, and reduce the cutting speed. Replace the blade. Refer to Blade Tension on Page 35, and adjust as required.
Blade wears on one side.	<ol style="list-style-type: none"> The blade guides are worn or mis-adjusted. The blade guide slide bracket is loose. The wheels are out of alignment. 	<ol style="list-style-type: none"> Refer to Blade Guides on Page 22 and replace or adjust. Tighten the blade guide bracket. Refer to Blade Tracking on Page 36, and adjust as required.
Teeth are ripping from the blade.	<ol style="list-style-type: none"> The feed pressure is too heavy and the blade speed is too slow; or the blade TPI is too coarse for the workpiece. The workpiece is vibrating in the vise. The blade gullets are loading up with chips. 	<ol style="list-style-type: none"> Refer to Blade Selection on Page 23 and decrease the feed pressure. Refer to Feed Rate on Page 24, and adjust as required. Re-clamp the workpiece in the vise, and use a jig if required. Use a coarser-tooth blade.
The cuts are crooked.	<ol style="list-style-type: none"> The feed pressure is too high. The guide bearings are out of adjustment, or too far away from the workpiece. The blade tension is low. The blade is dull. The blade speed is wrong. 	<ol style="list-style-type: none"> Refer to Feed Rate on Page 24, and adjust as required. Refer to Blade Guides on Page 22 and replace or adjust. Refer to Blade Tension on Page 35, and adjust as required. Refer to Blade Change on Page 34 and replace the blade. Refer to Blade Speed on Page 24 and adjust as required.



Blade Change

⚠ CAUTION

CUTTING HAZARD! Blades are sharp! Wear heavy leather gloves when handling blades to prevent cuts.

Blades should be changed when they become dull, damaged, or when you are using materials that require a blade of a certain type or tooth count.

To change the blade on the bandsaw:

1. UNPLUG THE BANDSAW!
2. Raise the bow of the bandsaw about six inches, lock in position by turning the feed control knob to the right to close the feed control valve.
3. Loosen and slide both blade guides toward the center of the bow.

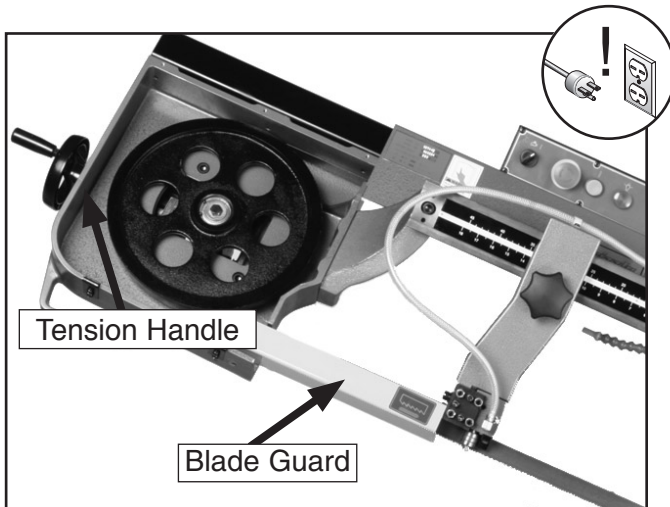

Figure 37. Tension handle and blade.

4. Remove the two screws to open the upper blade guard (see **Figure 38**).

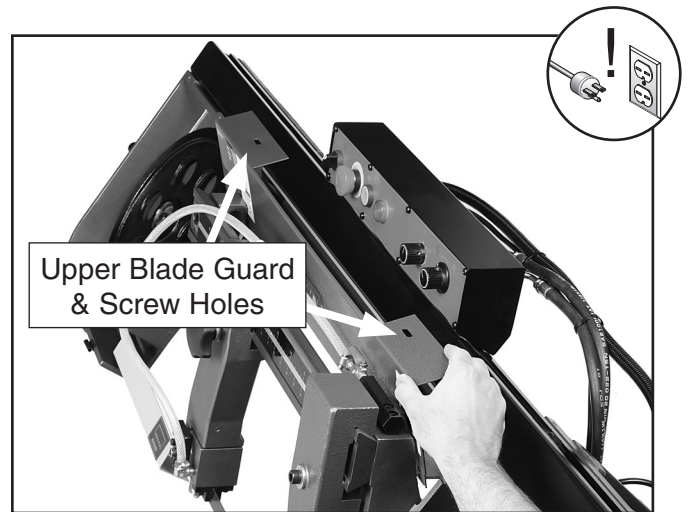

Figure 38. Opened upper blade guard.

5. Open both wheel covers and clean out all the chips and shavings.
6. Loosen the blade tension handle in **Figure 37** and slip the old blade off of the wheels then out of the blade guide roller bearings.
7. Install the new blade into the front and rear blade guide roller bearings, as shown in **Figure 39**, then around the bottom and top wheels.

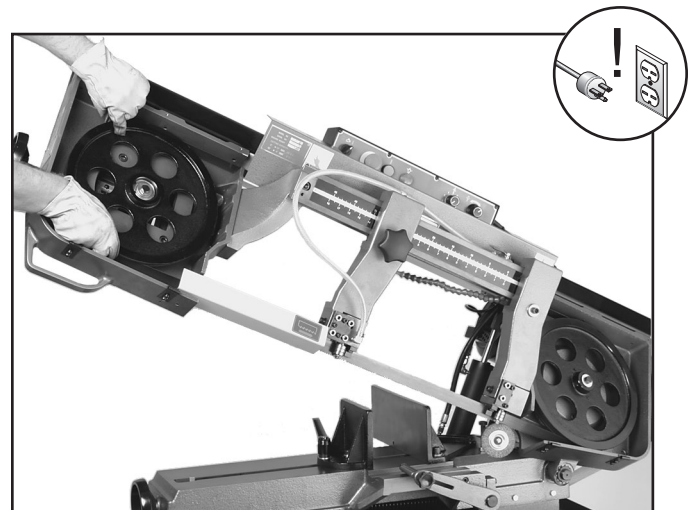

Figure 39. Installing the blade.



Note: It is sometimes possible to flip the blade inside out, in which case the blade will be installed in the wrong direction. Check to make sure the blade teeth are facing toward the workpiece, as shown in **Figure 40**, after mounting on the bandsaw. Some blades will have a directional arrow as a guide.

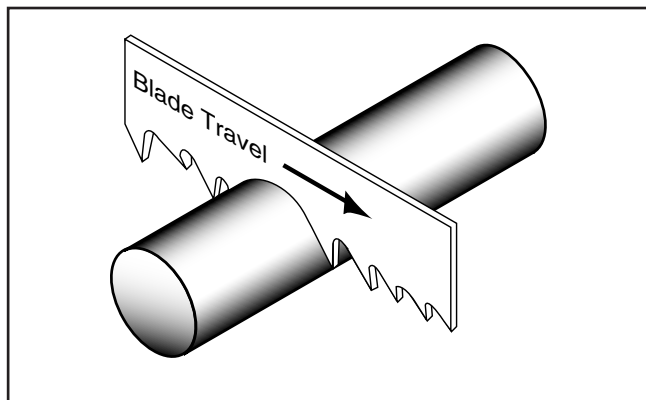

Figure 40. Blade cutting direction.

8. Apply a light amount of tension to hold the blade in place. Work your way around the blade to adjust the position so the back of the blade is against the flange of the wheels.
9. Complete the blade change by following the steps in **Blade Tension & Tracking**.

Blade Tension & Tracking

Proper blade tension is essential to long blade life, straight cuts, and efficient cutting. The Model G9744Z features a blade tension indicator to assist you with blade tensioning.

Two major signs that you do not have proper blade tension are: 1) the blade stalls in the cut and slips on the wheels, and 2) the blade frequently breaks from being too tight.

NOTICE

Loosen blade tension at the end of each day to prolong blade life.

To tension the blade on the bandsaw:

1. Turn the blade tension handle clockwise to tension the blade.
2. Use the graduated scale on the blade tension indicator (**Figure 41**) to determine blade tension in PSI.

—For carbon blades, the blade tension should be 20,000 PSI.

—For bi-metal blades, like the one supplied with your machine, the blade should be tensioned from 30,000 to 35,000 PSI.

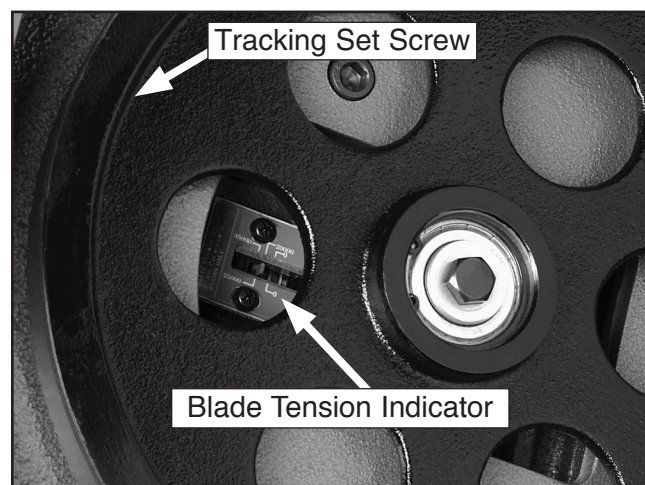

Figure 41. Blade tension indicator.

3. To fine tune blade tension, use a blade tensioning gauge, like the one found in **SECTION 5: ACCESSORIES** on **Page 28**. Please follow the instructions included with your gauge and the blade manufacturer's recommendations on blade tension.

Continued on next page →



The blade tracking has been properly set at the factory. The tracking will rarely need to be adjusted if the bandsaw is used properly.

To adjust the blade tracking on the bandsaw:

1. Loosen or tighten the tracking set screw in **Figure 42** until the blade is tracking properly. The blade is tracking properly when the back of the blade is lightly touching the flange of both wheels.

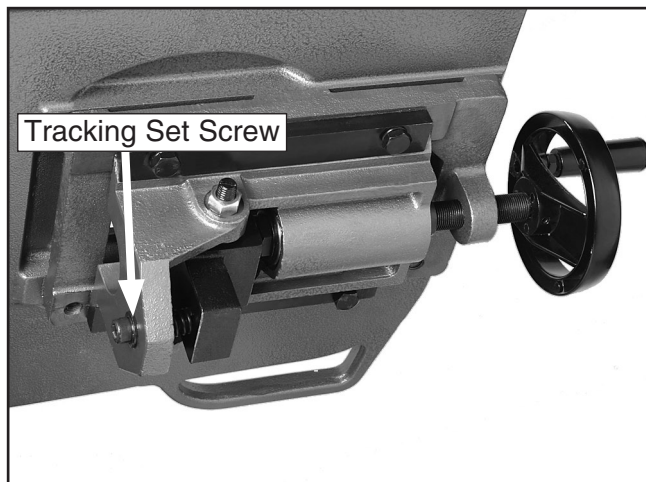

Figure 42. Tracking set screw.

2. Remove the V-belt from the motor pulley and spin either wheel by hand to observe how the blade is tracking. Make sure the blade teeth are not cutting into any part of the saw. Adjust as needed.

Blade Guide Bearings

The blade guide bearings are adjusted at the factory but due to shipping and storage may need adjustment. Use **Figures 43 & 44** to guide you through the following steps.

To adjust the blade guide bearings:

1. Before making adjustments, make sure the blade is tensioned and tracking correctly.
2. UNPLUG THE BANDSAW!
3. Raise the bow high enough to give you room to work, then lock in place.
4. Remove both blade guards.
5. The back of the blade (A) in **Figure 43** should make light contact with the backing bearing (C).

—If it does not, loosen the set screw (B) shown in **Figure 43**, and move the bearing (C) up or down until it lightly touches the back of the blade.

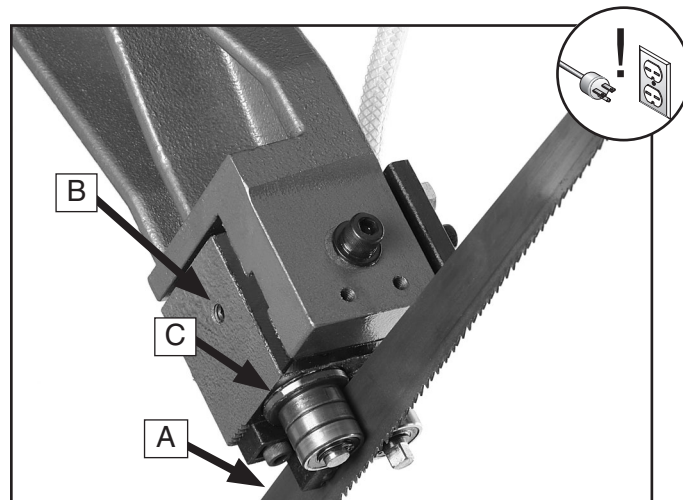

Figure 43. Blade guide adjustments.

The blade guide roller bearings also need to be adjusted. The front bearing is mounted on an eccentric and can be easily adjusted to suit the blade thickness.

To adjust the blade guide roller bearings:

1. Loosen the set screw shown in **Figure 44** to allow the eccentric bushing to turn.



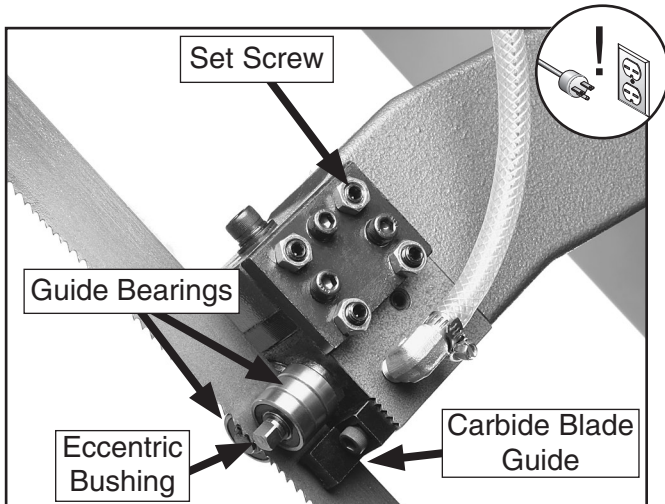

Figure 44. More blade guide adjustments.

2. Turn the square nut on the eccentric shaft to adjust the distance of the guide bearing. The guide bearings and blade should make light contact or have a maximum clearance of 0.002".
3. Adjust the carbide blade guides so they make the same contact with the blade as the bearings.
4. Adjust the eccentric blade guide roller bearing on the front arm the same way.

Squaring Blade to Table

This adjustment has been made at the factory and should not need to be adjusted under normal circumstances. However, if you find the saw is not cutting square, you may need to adjust the blade. Only make this adjustment after factors such as excessive feed rate or the blade guide being set too far away from the workpiece have been ruled out.

To square the blade the to the table:

1. UNPLUG THE BANDSAW!
2. Examine your workpiece for clues as to which way the blade is twisted, or Set up a machinist square on the table and blade as shown in **Figure 45**.

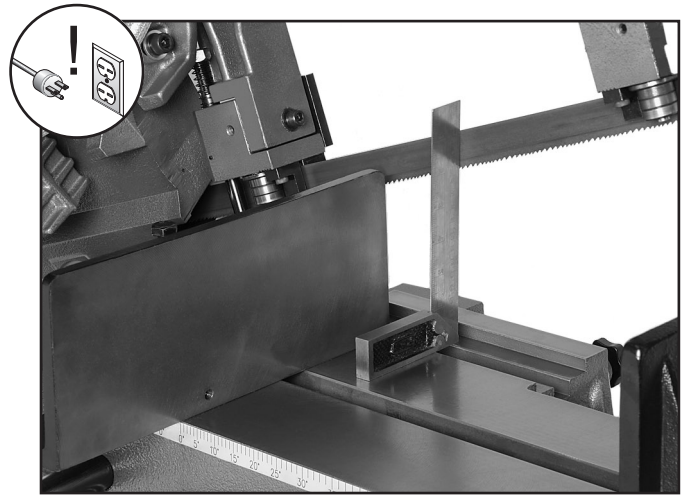

Figure 45. Square blade to table.

3. Check for gaps along several points of the blade length between the two blade guides. Set the machinist square between the blade teeth for a more accurate reading.
4. Adjust the blade by loosening the lock nuts and turning the set screws. This will cause the bearing bracket to pivot (see **Figure 46**).

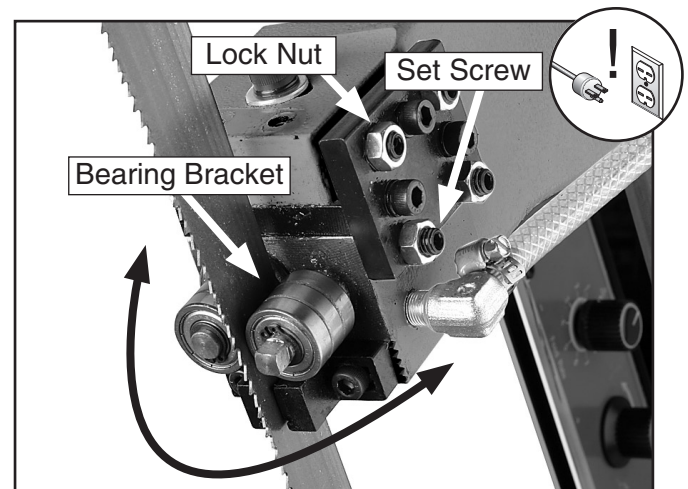

Figure 46. Bearing block pivot.

5. Adjust the set screws in pairs. Tightening the upper pair will pivot the bearing block toward the table. Tightening the lower pair will pivot the bearing bracket away from the table.
6. Cut a small section from a scrap piece of material with a known square end and measure for uniform thickness. If the thickness is not uniform, repeat **Steps 1-5** until your personal requirements are met.



Electrical Components

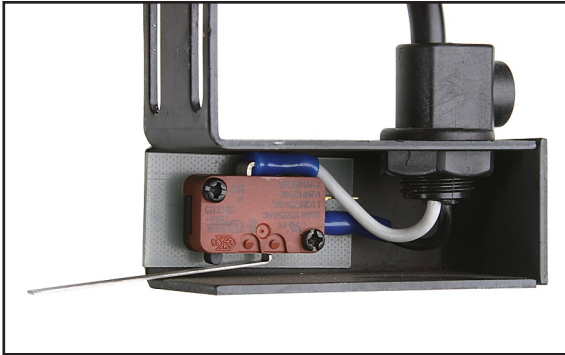

Figure 47. Limit switch (SQ1).

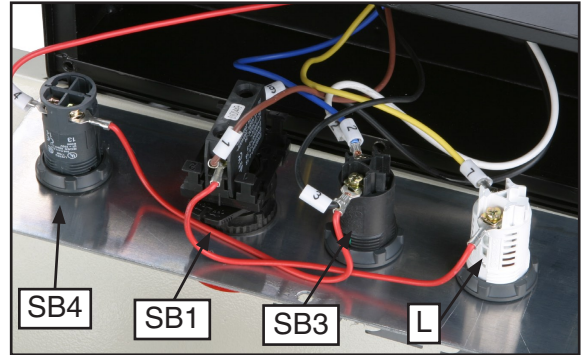

Figure 49. Control panel wiring.



Figure 48. Junction box (M1).

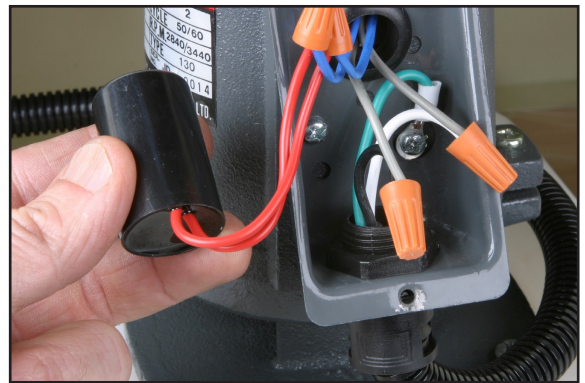

Figure 50. Pump motor wiring and capacitor (M2).

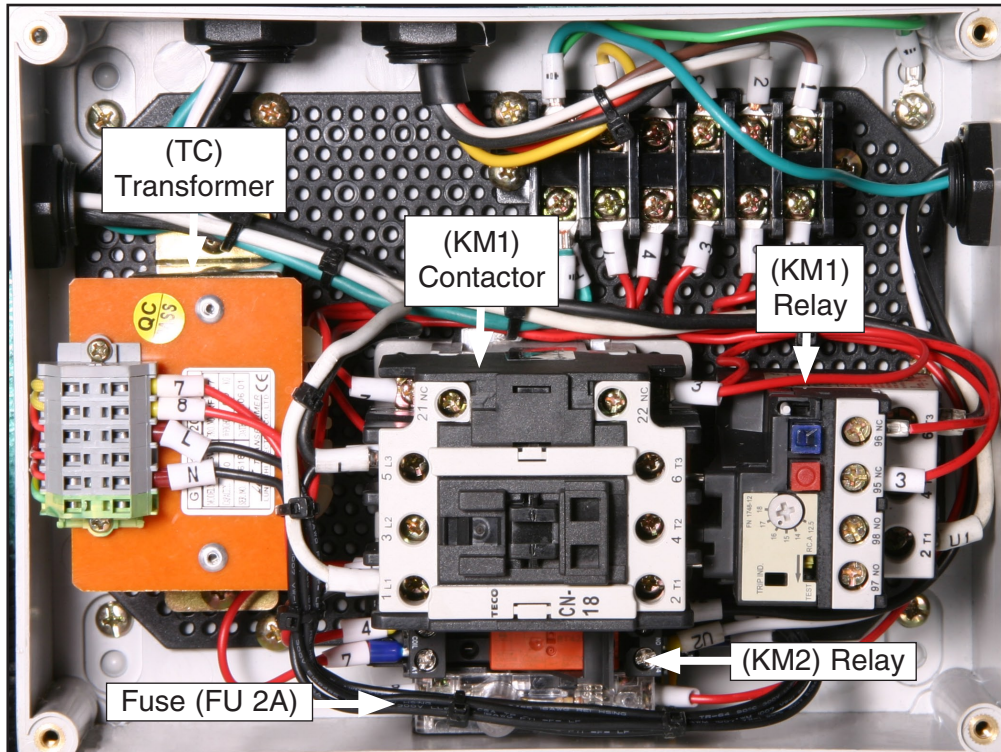
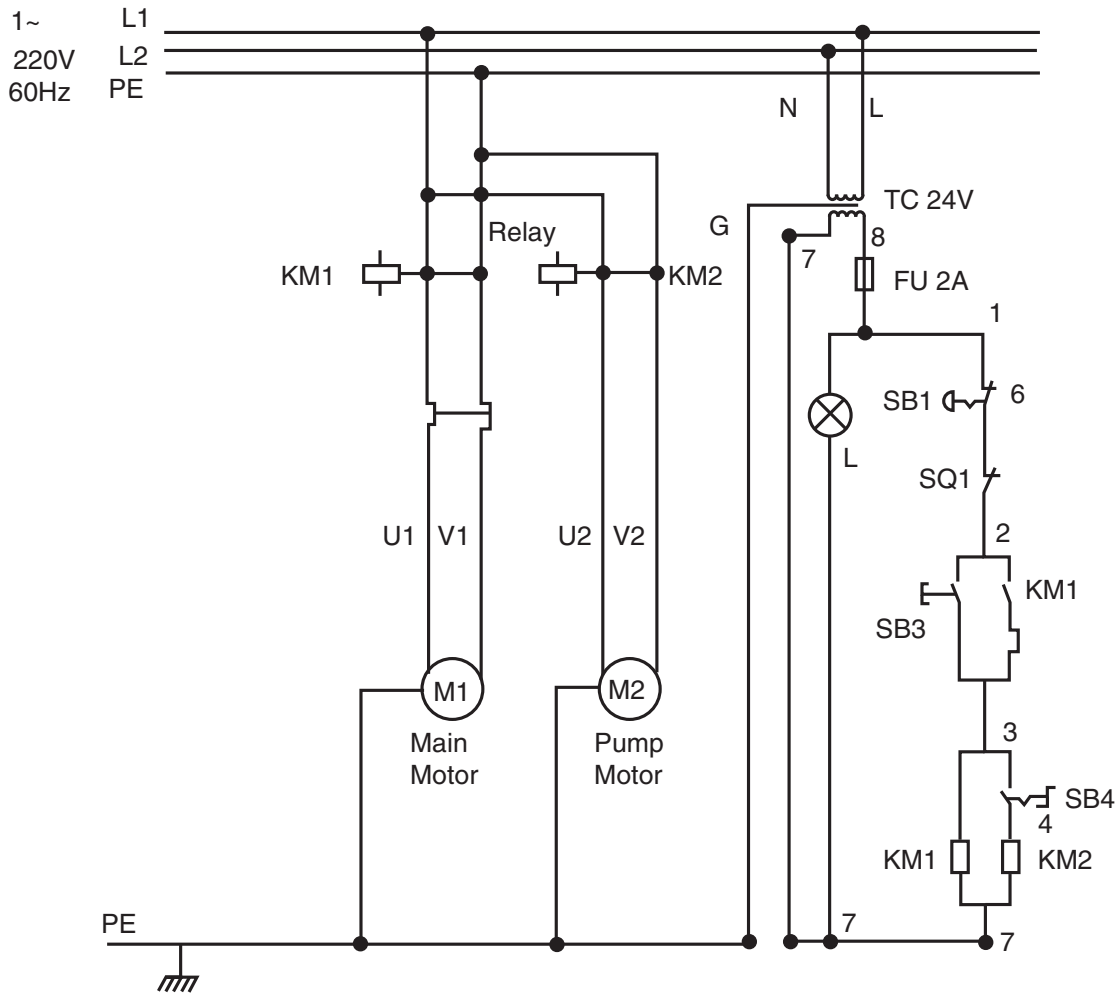
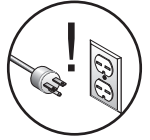

Figure 51. G9744Z Contactor & relay electrical box.



Model G9744Z 220V Wiring Diagram



LEGEND	
M	= Motor
KM1	= Contactor Main Motor
KM2	= Pump Motor Relay
KM1	= Thermal Relay Main Motor
L	= Indicator Lamp
SB1	= Emergency Stop Button
SB3	= Start Button
SB4	= Pump Motor Switch
SQ1	= Limit Switch
TC	= Transformer for Control System (24V)
FU2A	= Fuse



Blade Guide Parts Breakdown

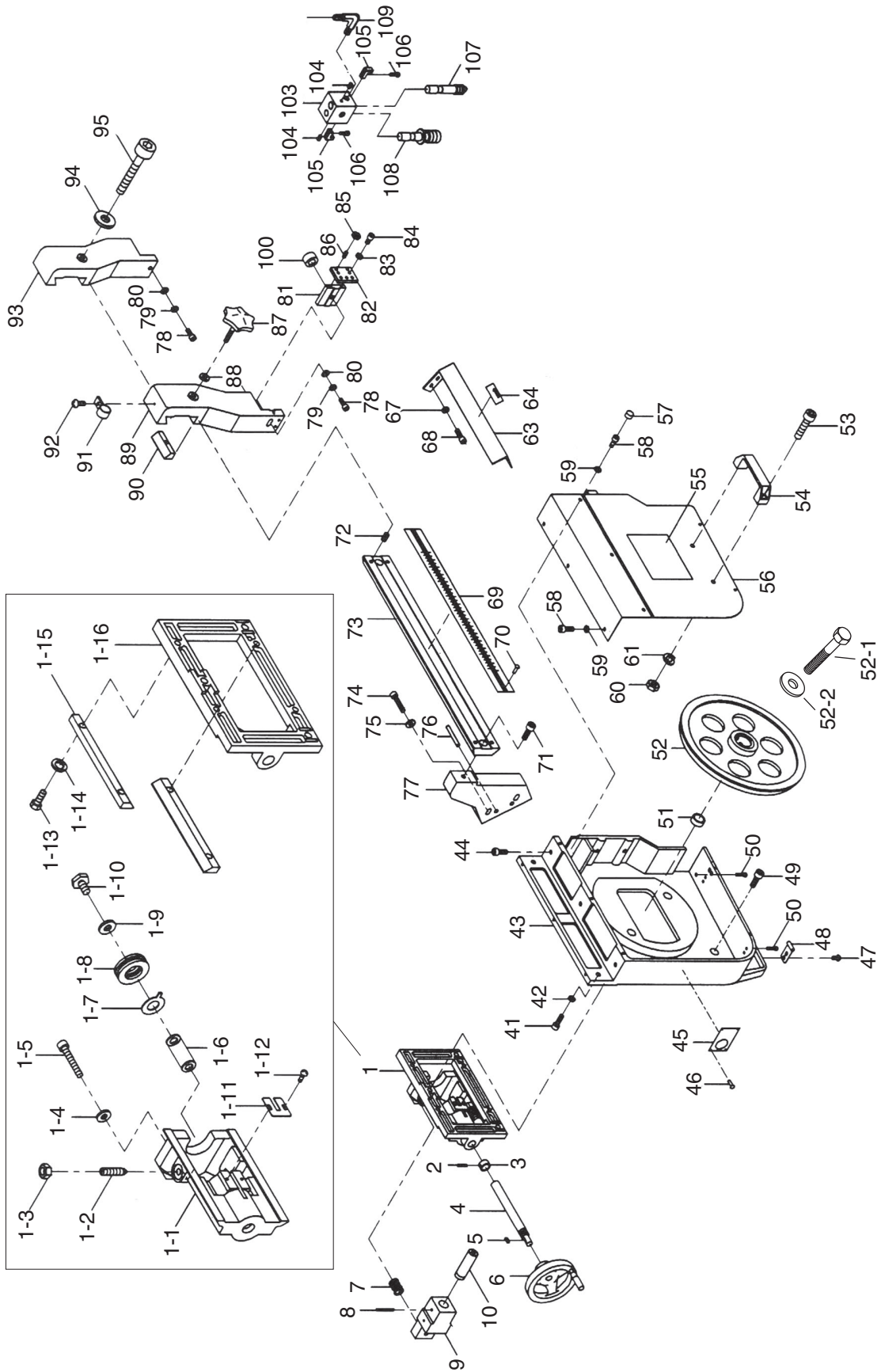

Drive Wheel Parts Breakdown

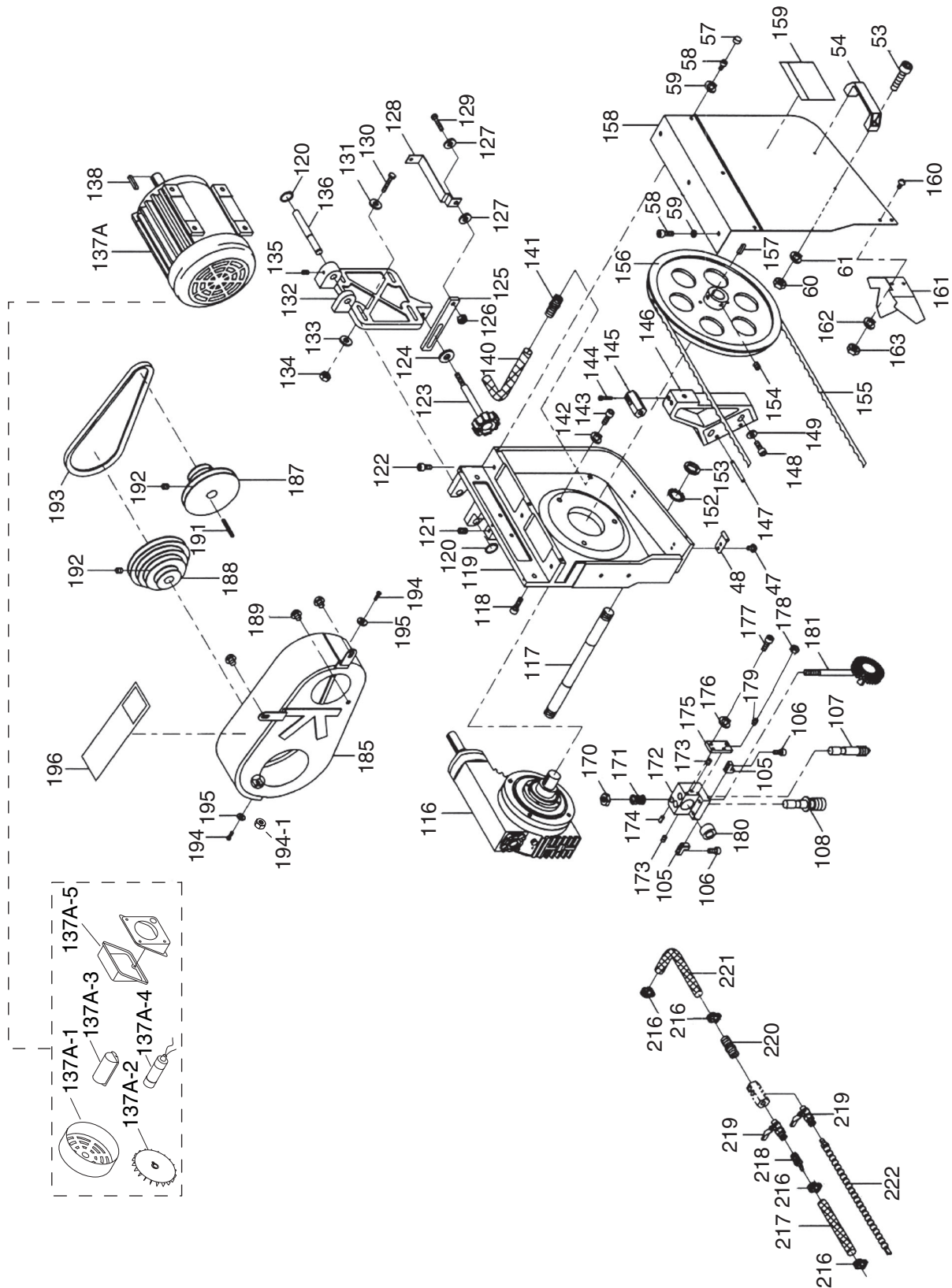

Main Parts Breakdown

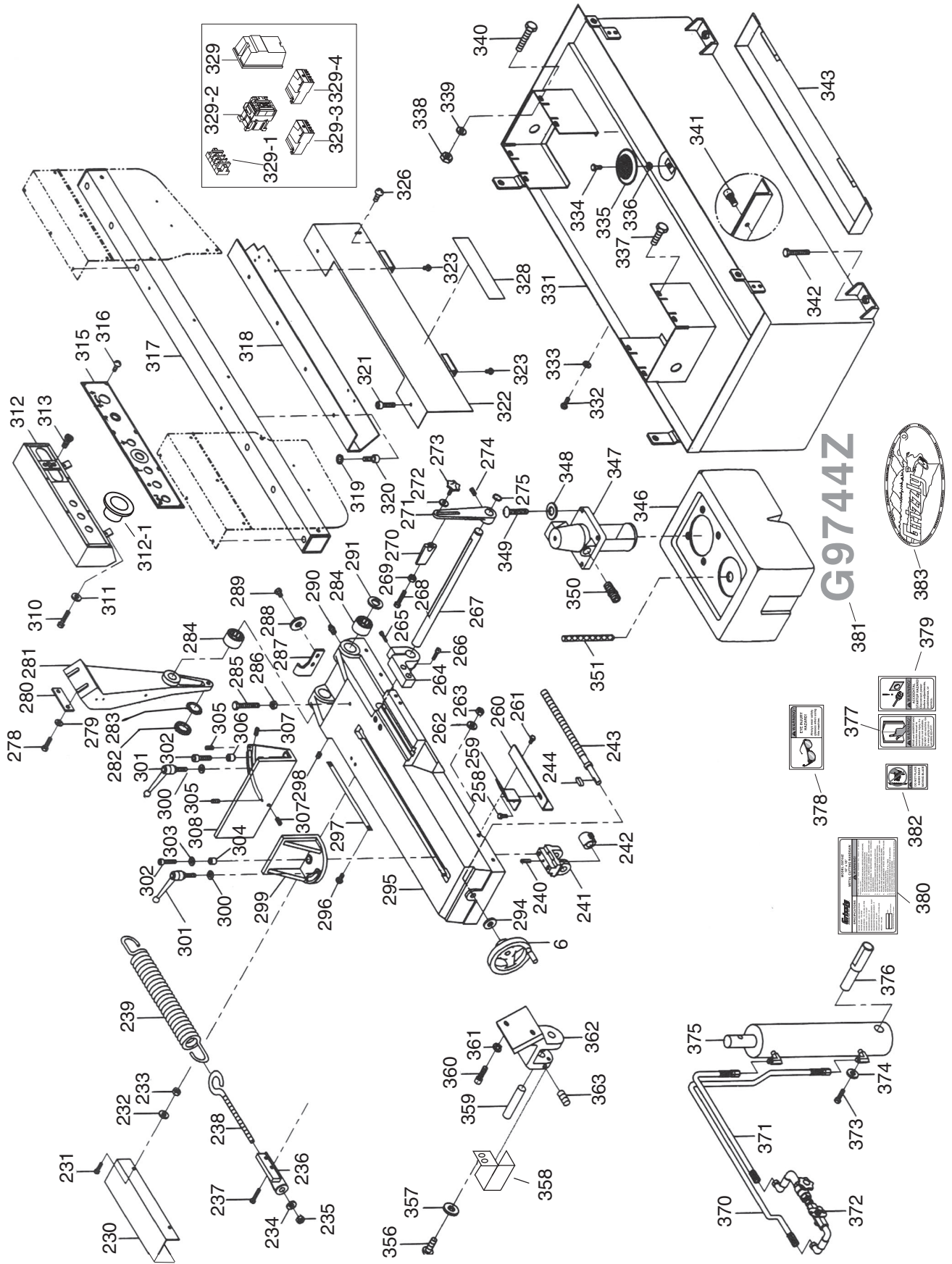

Parts List

REF	PART #	DESCRIPTION
1	P9744Z001	SLIDE SET
1-1	P9744Z001-1	SLIDE
1-2	P9744Z001-2	SPECIAL SET SCREW
1-3	PN10	HEX NUT 7/16-20
1-4	PW04M	FLAT WASHER 10MM
1-5	PSB134M	CAP SCREW M10-1.5 X 65
1-6	P9744Z001-6	DISC SPRING
1-7	P9744Z001-7	INDICATOR DIAL
1-8	P9744Z001-8	BEARING 51204
1-9	PW01	FLAT WASHER 1/2
1-10	P9744Z001-10	SPECIAL SCREW
1-11	P9744Z001-11	SCALE
1-12	PS05M	PHLP HD SCR M5-.8 x 8
1-13	PB32M	HEX BOLT M10-1.5 x 25
1-14	PLW06M	LOCK WASHER 10MM
1-15	P9744Z001-15	GIB
1-16	P9744Z001-16	BRACKET
2	PRP49M	ROLL PIN 5 X 25
3	P9744Z003	COLLAR
4	P9744Z004	LEADSCREW
5	PK20M	KEY 5 X 5 X 15
6	P9744Z006	HANDWHEEL & HANDLE
7	P9744Z007	COMPRESSION SPRING
8	PRP30M	ROLL PIN 5 X 50
9	P9744Z009	BRACKET
10	P9744Z010	SHAFT
41	PSB72M	CAP SCREW M10-1.5 X 30
42	PLW06M	LOCK WASHER 10MM
43	P9744Z043	IDLER WHEEL BOX
44	PSB130M	CAP SCREW M10-1.5 X 16
45	P9744Z045	TENSION LABEL
46	P1005619	RIVET 2
47	PS68M	PHLP HD SCR M6-1 X 10
48	P9744Z048	BRACKET
49	PSB77M	CAP SCREW M12-1.75 X 30
50	PSB06M	CAP SCREW M6-1 X 25
51	P9744Z051	BUSHING
52	P9744Z052	IDLER WHEEL
52-1	PB70M	HEX BOLT M10-1.5 X 16
52-2	PW04M	FLAT WASHER 10MM
53	PSB11M	CAP SCREW M8-1.25 X 16
54	P9744Z054	HANDLE
55	P9744Z055	SPEED INDICATOR LABEL
56	P9744Z056	IDLER WHEEL COVER
57	P9744Z057	PLASTIC BUSHING
58	PSB04M	CAP SCREW M6-1 X 10
59	PLW02	LOCK WASHER 1/4
60	PN03M	HEX NUT M8-1.25
61	PLW01	LOCK WASHER 5/16
63	P9744Z063	BLADE GUARD
64	P9744Z064	BLADE LABEL

REF	PART #	DESCRIPTION
67	PLW02	LOCK WASHER 1/4
68	PSB04M	CAP SCREW M6-1 X 10
69	P9744Z069	SCALE
70	P1005619	RIVET 2
71	PSB77M	CAP SCREW M12-1.75 X 30
72	PSS09M	SET SCREW M8-1.25 X 20
73	P9744Z073	COLUMN
74	PSB84M	CAP SCREW M10-1.5 X 35
75	PW04M	FLAT WASHER 10MM
76	PRP49M	ROLL PIN 5 X 25
77	P9744Z077	LEFT COLUMN SUPPORT
78	PSB05M	CAP SCREW M8-1.25 X 50
79	PLW04M	LOCK WASHER 8MM
80	PLW01	LOCK WASHER 5/16
81	P9744Z081	SUPPORT SEAT
82	P9744Z082	ADJ FIXING PLATE (IDLER)
83	PLW02	LOCK WASHER 1/4
84	PSB02M	CAP SCREW M6-1 X 20
85	PN03M	HEX NUT M8-1.25
86	PSS09M	SET SCREW M8-1.25 X 20
87	P9744Z087	BLADE ADJUSTABLE KNOB
88	PW04M	FLAT WASHER 10MM
89	P9744Z089	ARM (LEFT)
90	P9744Z090	GIB
91	P9744Z091	HOSE CLAMP
92	PS05M	PHLP HD SCR M5-.8 X 8
93	P9744Z093	ARM (RIGHT)
94	PW04M	FLAT WASHER 10MM
95	PSB71M	CAP SCREW M10-1.5 X 60
100	P9744Z100	BEARING SPACER
103	P9744Z103	BEARING BRACKET (IDLER)
104	PSS20M	SET SCREW M8-1.25 X 8
105	P9744Z105	CARBIDE GUIDE
106	PSB02M	CAP SCREW M6-1 X 20
107	P9744Z107	ECCENTRIC SHAFT SET
108	P9744Z108	BEARING SHAFT ASSY
109	P9744Z109	MICRO CONTROL BLOCK
116	P9744Z116	GEAR BOX ASSY
117	P9744Z117	PIVOT SHAFT
118	PSB72M	CAP SCREW M10-1.5 X 30
119	P9744Z119	DRIVE WHEEL BOX
120	PR05M	EXT RETAINING RING 15MM
121	PSS09M	SET SCREW M8-1.25 X 20
122	PSB130M	CAP SCREW M10-1.5 X 16
123	P9744Z123	BELT TENSION KNOB
124	PW04M	FLAT WASHER 10MM
125	P9744Z125	MOTOR ADJUSTABLE ROD
126	PN03M	HEX NUT M8-1.25
127	PW07	FLAT WASHER 5/16
128	P9744Z128	BRACKET
129	PB15M	HEX BOLT M8-1.25 X 40



Parts List

REF	PART #	DESCRIPTION
130	PB15M	HEX BOLT M8-1.25 X 40
131	PW07	FLAT WASHER 5/16
132	P9744Z132	MOTOR PLATE
133	PW07	FLAT WASHER 5/16
134	PN03M	HEX NUT M8-1.25
135	PSS01M	SET SCREW M6-1 X 10
136	P9744Z136	PIVOT SHAFT
137A	P9744Z137A	2 HP MOTOR 220V
137A-1	P9744Z137A-1	MOTOR COVER
137A-2	P9744Z137A-2	MOTOR FAN
137A-3	P9744Z137A-3	CAPACITOR COVER
137A-4	P9744Z137A-4	CAPACITOR 800 MFD 125 VAC
137A-5	P9744Z137A-5	JUNCTION BOX
138	PK20M	KEY 5 X 5 X 15
140	P9744Z140	HOSE 5/8 X 600MM
141	P9744Z141	HOSE FITTING PT 1/2"
142	PLW06M	LOCK WASHER 10MM
143	PSB61M	CAP SCREW M10-1.5 X 20
144	PSB06M	CAP SCREW M6-1 X 25
145	P9744Z145	BRACKET
146	P9744Z146	COLUMN RIGHT SUPPORT
147	PRP49M	ROLL PIN 5 X 25
148	PSB84M	CAP SCREW M10-1.5 X 35
149	PW04M	FLAT WASHER 10MM
152	P9744Z152	STAR WASHER AW05
153	P9744Z153	COLLAR
154	PSS20M	SET SCREW M8-1.25 X 8
155	G6436	BLADE 129-3/8 X 1 X .035 5-8VP
156	P9744Z156	DRIVE WHEEL
157	PK61M	KEY 7 X 7 X 30
158	P9744Z158	WHEELCOVER
159	P9744Z159	WARNING LABEL
160	PS68M	PHLP HD SCR M6-1 X 10
161	P9744Z161	BRUSH COVER
162	PLW02	LOCK WASHER 1/4
163	PN03M	HEX NUT M8-1.25
170	PN09M	HEX NUT M12-1.75
171	P9744Z171	COMPRESSION SPRING
172	P9744Z172	BLADE ADJUSTABLE DRIVE
173	PSS20M	SET SCREW M8-1.25 X 8
174	PRP44M	ROLL PIN 3 X 10
175	P9744Z175	ADJ FIXING PLATE (DRIVE)
176	PLW02	LOCK WASHER 1/4
177	PSB02M	CAP SCREW M6-1 X 20
178	PN03M	HEX NUT M8-1.25
179	PSS01M	SET SCREW M6-1 X 10
180	P9744Z180	BEARING SPACER

REF	PART #	DESCRIPTION
181	P9744Z181	BRUSH ASSY
185	P9744Z185	MOTOR PULLEY COVER
187	P9744Z187	SPINDLE PULLEY
188	P9744Z188	MOUNT PULLEY
189	PS39M	PHLP HD SCR M8-1.25 X 10
191	PK20M	KEY 5 X 5 X 15
192	PSS16M	SET SCREW M8-1.25 X 10
193	PVA32	V-BELT A-32 4L320
194	P9744Z194	TRIANGLE SCREW 5/16 -18 X 3/4"
194-1	PN02	HEX NUT 5/16-18
195	PW07	FLAT WASHER 5/16
196	P9744Z196	SPEED INDICATOR LABEL
216	P9744Z216	HOSE CLAMP 1/2"
217	P9744Z217	HOSE 5/16 X 600MM
218	P9744Z218	HOSE FITTING PT1/4 X 1/4
219	P9744Z219	VALVE PT 1/4
220	P9744Z220	HOSE FITTING PT 1/4 X 1/2
221	P9744Z221	HOSE 1/4 X 1400MM
222	P9744Z222	NOZZLE PT 1/4
230	P9744Z230	SPRING COVER
231	PB26M	HEX BOLT M8-1.25 X 30
232	PW07	FLAT WASHER 5/16
233	PN03M	HEX NUT M8-1.25
234	PW01	FLAT WASHER 1/2
235	PN13	HEX NUT 1/2-13
236	P9744Z236	SPRING BRACKET
237	PB15M	HEX BOLT M8-1.25 X 40
238	P9744Z238	EYE BOLT
239	P9744Z239	EXTENSION SPRING
240	PRP10M	ROLL PIN 5 X 36
241	P9744Z241	BRACKET
242	P9744Z242	ACME NUT ASSY
243	P9744Z243	ACME SCREW
244	PK20M	KEY 5 X 5 X 15
258	PB87M	HEX BOLT M8-1.25 X 15
259	P9744Z259	FIXED PLATE
260	P9744Z260	FIXED PLATE
261	PB17M	HEX BOLT M8-1.25 X 10
262	PW07	FLAT WASHER 5/16
263	PN03M	HEX NUT M8-1.25
264	P9744Z264	BRACKET
265	PSB48M	CAP SCREW M6-1 X 35
266	PSB13M	CAP SCREW M8-1.25 X 30
267	P9744Z267	DISTANCE SET ROD
268	PB32M	HEX BOLT M10-1.5 x 25
269	PN03M	HEX NUT M8-1.25



Parts List

REF	PART #	DESCRIPTION
270	P9744Z270	DISTANCE SET BRACKET
271	P9744Z271	SUPPORT ROD
272	PLW02	LOCK WASHER 1/4
273	P9744Z273	THUMB SCREW
274	PSS01M	SET SCREW M6-1 X 10
275	PR11M	EXT RETAINING RING 25MM
278	PB14M	HEX BOLT M10-1.5 X 35
279	PLW06M	LOCK WASHER 10MM
280	P9744Z280	BUSHING
281	P9744Z281	REAR PIVOT BRACKET
282	P9744Z282	COLLAR
283	P9744Z152	STAR WASHER AW05
284	P9744Z284	BEARING 6904RNA
285	PB141M	HEX BOLT M12-1.75 X 80
286	PN09M	HEX NUT M12-1.75
287	P9744Z287	POSITION SET BRACKET
288	PW07	FLAT WASHER 5/16
289	PSB14M	CAP SCREW M8-1.25 X 20
290	P9744Z290	GREASE NIPPLE
291	P9744Z291	BUSHING
294	PW04	FLAT WASHER 7/16
295	P9744Z295	BASE
296	PS05M	PHLP HD SCR M5-.8 X 8
297	P9744Z297	DEGREE SCALE
298	PSS16M	SET SCREW M8-1.25 X 10
299	P9744Z299	FRONT VISE JAW
300	PW04M	FLAT WASHER 10MM
301	P9744Z301	WISE JAW HANDLE
302	PSB72M	CAP SCREW M10-1.5 X 30
303	PW04M	FLAT WASHER 10MM
304	P9744Z304	BUSHING
305	PSS01M	SET SCREW M6-1 X 10
306	P9744Z306	BUSHING
307	PSS19M	SET SCREW M8-1.25 X 30
308	P9744Z308	REAR VISE JAW
310	PB02M	HEX BOLT M6-1 X 12
311	PLW02	LOCK WASHER 1/4
312	P9744Z312	CONTROL BOX
312-1	P9744Z312-1	EMERGENCY STOP SWITCH
313	PS14M	PHLP HD SCR M6-1 X 12
315	P9744Z315	NAME PLATE
316	PS70M	PHLP HD SCR M5-1 X 8
317	P9744Z317	COLUMN
318	P9744Z318	LOWER BLADE GUARD
319	PLW01	LOCK WASHER 5/16
320	PB03M	HEX BOLT M8-1.25 X 16
321	PSB04M	CAP SCREW M6-1 X 10
322	P9744Z322	UPPER BLADE COVER
323	PS70M	PHLP HD SCR M5-1 X 8

REF	PART #	DESCRIPTION
326	PS70M	PHLP HD SCR M5-1 X 8
328	P9744Z328	NAME PLATE
329	P9744Z329	COMPLETE ELECTRICAL BOX
329-1	P9744Z329-1	COMPLETE FUSE HOLDER
329-2	P9744Z329-2	CONTACTOR LCK09
329-3	P9744Z329-3	THERMAL OVERLOAD LR7K0332
329-4	P9744Z329-4	RELAY 240/24V
331	P9744Z331	STAND
332	PS68M	PHLP HD SCR M6-1 X 10
333	PLW03M	LOCK WASHER 6MM
334	PB18M	HEX BOLT M6-1 X 15
335	P9744Z335	FILTER
336	PN01M	HEX NUT M6-1
337	PB26M	HEX BOLT M8-1.25 X 30
338	PN03M	HEX NUT M8-1.25
339	PW07	FLAT WASHER 5/16
340	PSB12M	CAP SCREW M8-1.25 X 40
341	PSB30M	CAP SCREW M6-1 X 45
342	PB22M	HEX BOLT M8-1.25 X 50
343	P9744Z343	CHIP TRAY
346	P0561082	COOLANT TANK
347	P9744Z347	COOLANT PUMP
348	PW06	FLAT WASHER 1/4
349	PS07	PHLP HD SCR 1/4-20 X 3/8
350	P9744Z350	COUPLER PT 1/2 X 1/4
351	P9744Z351	HOSE 3/4 X 1.5
356	PS68M	PHLP HD SCR M6-1 X 10
357	PLW02	LOCK WASHER 1/4
358	P9744Z358	SWITCH BRACKET
359	P9744Z359	PIVOT PIN
360	PSB13M	CAP SCREW M8-1.25 X 30
361	PLW01	LOCK WASHER 5/16
362	P9744Z362	CYLINDER UPPER BRACKET
363	PSS01M	SET SCREW M6- X 10
370	P9744Z370	HOSE W/TUBE FITTING
371	P9744Z371	HOSE W/TUBE FITTING
372	P9744Z372	VALVE
373	PB03M	HEX BOLT M8-1.25 X 16
374	PW07	FLAT WASHER 5/16
375	P9744Z375	CYLINDER ASSY
376	P9744Z376	PIVOT SHAFT
377	PLABEL-12	READ MANUAL LABEL
378	PLABEL-01	SAFETY GLASSES LABEL
379	PLABEL-02	UNPLUG POWER LABEL
380	P9744Z480	MACHINE ID LABEL
381	P9744Z481	G9744Z LABEL
382	P9744Z482	BLADE SAFETY LABEL
383	G8588	LOGO PLATE



WARRANTY AND RETURNS

Grizzly Industrial, Inc. warrants every product it sells for a period of **1 year** to the original purchaser from the date of purchase. This warranty does not apply to defects due directly or indirectly to misuse, abuse, negligence, accidents, repairs or alterations or lack of maintenance. This is Grizzly's sole written warranty and any and all warranties that may be implied by law, including any merchantability or fitness, for any particular purpose, are hereby limited to the duration of this written warranty. We do not warrant or represent that the merchandise complies with the provisions of any law or acts unless the manufacturer so warrants. In no event shall Grizzly's liability under this warranty exceed the purchase price paid for the product and any legal actions brought against Grizzly shall be tried in the State of Washington, County of Whatcom.

We shall in no event be liable for death, injuries to persons or property or for incidental, contingent, special, or consequential damages arising from the use of our products.

To take advantage of this warranty, contact us by mail or phone and give us all the details. We will then issue you a "Return Number," which must be clearly posted on the outside as well as the inside of the carton. We will not accept any item back without this number. Proof of purchase must accompany the merchandise.

The manufacturers reserve the right to change specifications at any time because they constantly strive to achieve better quality equipment. We make every effort to ensure that our products meet high quality and durability standards and we hope you never need to use this warranty.

Please feel free to write or call us if you have any questions about the machine or the manual.

Thank you again for your business and continued support. We hope to serve you again soon.





WARRANTY CARD

Name _____
 Street _____
 City _____ State _____ Zip _____
 Phone # _____ Email _____ Invoice # _____
 Model # _____ Order # _____ Serial # _____

The following information is given on a voluntary basis. It will be used for marketing purposes to help us develop better products and services. **Of course, all information is strictly confidential.**

1. How did you learn about us?

Advertisement Friend Catalog
 Card Deck Website Other:

2. Which of the following magazines do you subscribe to?

<input type="checkbox"/> Cabinet Maker	<input type="checkbox"/> Popular Mechanics	<input type="checkbox"/> Today's Homeowner
<input type="checkbox"/> Family Handyman	<input type="checkbox"/> Popular Science	<input type="checkbox"/> Wood
<input type="checkbox"/> Hand Loader	<input type="checkbox"/> Popular Woodworking	<input type="checkbox"/> Wooden Boat
<input type="checkbox"/> Handy	<input type="checkbox"/> Practical Homeowner	<input type="checkbox"/> Woodshop News
<input type="checkbox"/> Home Shop Machinist	<input type="checkbox"/> Precision Shooter	<input type="checkbox"/> Woodsmith
<input type="checkbox"/> Journal of Light Cont.	<input type="checkbox"/> Projects in Metal	<input type="checkbox"/> Woodwork
<input type="checkbox"/> Live Steam	<input type="checkbox"/> RC Modeler	<input type="checkbox"/> Woodworker West
<input type="checkbox"/> Model Airplane News	<input type="checkbox"/> Rifle	<input type="checkbox"/> Woodworker's Journal
<input type="checkbox"/> Modeltec	<input type="checkbox"/> Shop Notes	<input type="checkbox"/> Other:
<input type="checkbox"/> Old House Journal	<input type="checkbox"/> Shotgun News	

3. What is your annual household income?

\$20,000-\$29,000 \$30,000-\$39,000 \$40,000-\$49,000
 \$50,000-\$59,000 \$60,000-\$69,000 \$70,000+

4. What is your age group?

20-29 30-39 40-49
 50-59 60-69 70+

5. How long have you been a woodworker/metalworker?

0-2 Years 2-8 Years 8-20 Years 20+ Years

6. How many of your machines or tools are Grizzly?

0-2 3-5 6-9 10+

7. Do you think your machine represents a good value? Yes No

8. Would you recommend Grizzly Industrial to a friend? Yes No

9. Would you allow us to use your name as a reference for Grizzly customers in your area?
Note: We never use names more than 3 times. Yes No

10. Comments: _____

CUT ALONG DOTTED LINE

FOLD ALONG DOTTED LINE



Place Stamp Here



GRIZZLY INDUSTRIAL, INC.
P.O. BOX 2069
BELLINGHAM, WA 98227-2069



FOLD ALONG DOTTED LINE

Send a Grizzly Catalog to a friend:

Name _____
Street _____
City _____ State _____ Zip _____

TAPE ALONG EDGES--PLEASE DO NOT STAPLE

grizzly.com

TOOL WEBSITE

Buy Direct and Save with Grizzly® – Trusted, Proven and a Great Value!

*Visit Our Website Today And Discover
Why Grizzly® Is The Industry Leader!*

- SECURE ORDERING
- ORDERS SHIPPED WITHIN 24 HOURS
- E-MAIL RESPONSE WITHIN ONE HOUR

-OR-

Call Today For A **FREE**
Full Color Catalog

1-800-523-4777

